

Our great technology that will lead the world
WOOSUNG FLOWTEC Co., Ltd.

STRAINER PRODUCT GUIDE



Contents

A Company information

- Greetings
- General information
- Organization
- History
- Facility
- Certification
- Major customers

B Products introduction

- Simplex Strainers
- Duplex Strainers
- Y Strainers
- Tee Strainers
- Temporary Strainers
- MUD / Rose Boxes
- Reducing Piece / Bell Mouth

C Design data

- MESH-MM Conversion & open area chart
- Flow rates in pipes reference
- Open area calculation
- Conversion of units



Challenge & Creation based on Experience and Technology



**“Inexpensive insurance”
“Make your expensive equipment long-lasting”**

GREETING

Since founded in 1989, Woosung flowtec has majorly produced various kinds of strainers, filters, pipe fittings etc. and done our best to meet customer’s needs and satisfactions with “best quality”, “reasonable price”, and “on time delivery”.

As inexpensive insurance, our products have widely applicated and utilized in Offshore plant (FPSO, Drill ship, Platform, etc.), Onshore plant, Fresh water, unit, etc. And we have consistently exported strainers, filters, and pipe fittings to USA, Japan, Singapore, Saudi Arabia, UAE, Thailand, Algeria, India, Brazil, etc. with certified quality. Woosung flowtec has done our best to globalize by export our products to the world-wide.

Also, Woosung flowtec will keep the customer-friendly mind with the best quality by certified ISO9001(API), CE(PED), ISO14001 and OHSAS18001.

Woosung flowtec promises to be the world best company, pursuing new next level with challenge and creation, based on the policies, customer-minded and quality-minded.

President **CHO, YOUNG JE**



**Best quality
Optimal price
Observance of delivery**





World best product with high quality

6

7

WOOSUNG FLOWTEC Co.,Ltd.



GENERAL INFORMATION

Established	1989. 12. 16
Firm Name	WOOSUNG FLOWTEC Co., Ltd.
President Name	Young-Je Cho
Head Office & Factory	27, Mieumsandan 3-ro, Gangseo-gu, Busan, Korea
Service	Manufacture
Main Products	<ul style="list-style-type: none"> . SIMPLEX STRAINER . DUPLEX STRAINER . BUCKET STRAINER . Y-TYPE STRAINER . TEE STRAINER . TEMPORARY STRAINER . REDUCING PIECE . BELL MOUTH

www.woosungflowtec.com

ORGANIZATION

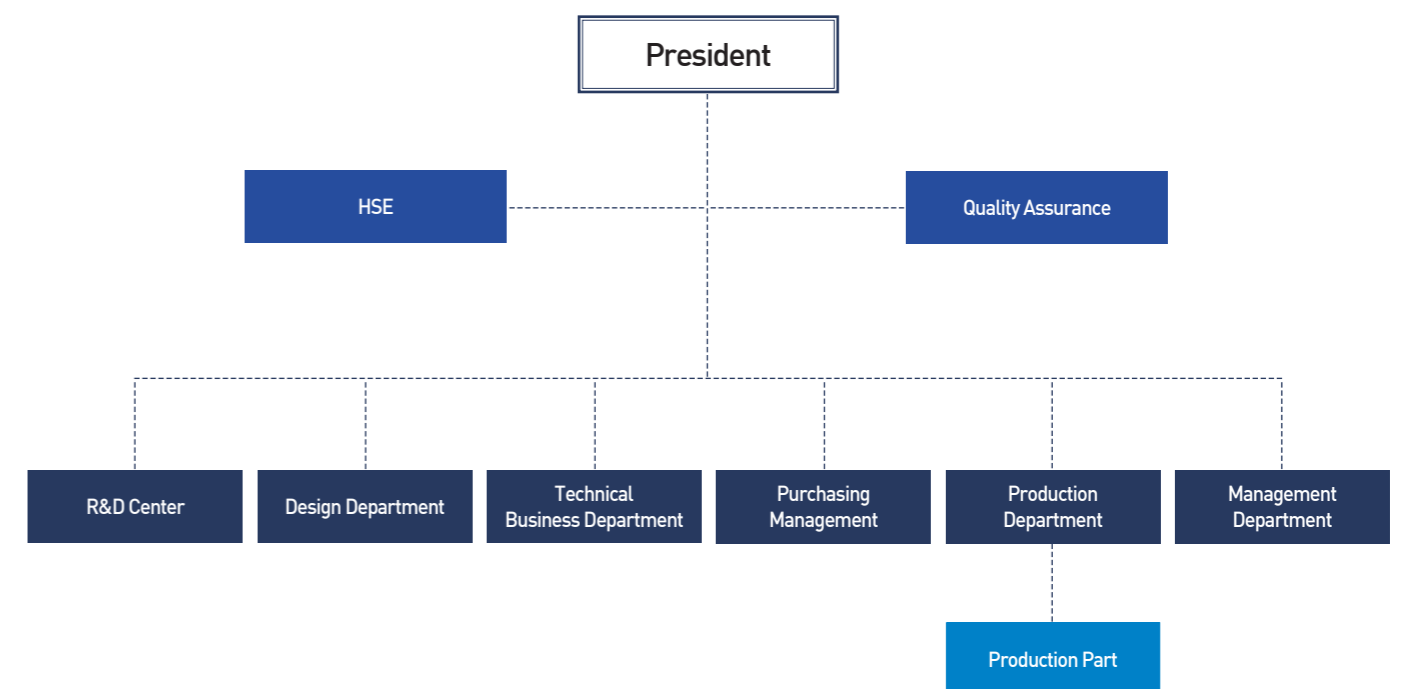

www.woosungflowtec.com



HISTORY

- 2018 04 Completion ceremony for the Test Shop
- 2015 02 Awarded from Ministry of Trade, Industry and Energy
- 2014 10 Head Office Moved to Mieumsandan Factory
- 2013 11 Converted the Company to WOOSUNG FLOWTEC Co., Ltd.
03 Sincerity tax payment award granted on the Taxation Day
- 2012 01 Obtained a patent on Strainer WW/WW Tee Type Strainer Filter
- 2011 08 Obtained a Design registration on Strainer WW/WW Tee Type Strainer Filter
- 2010 04 Obtained a Design registration on Trapezoid Filter
04 ISO 14001 Certificate of Registration
04 OHSAS 18001 Certificate of Registration
- 2009 06 CE Certificate of Registration
- 2008 12 Selected government support development of knowledge Economy
05 INNO-BIZ Certificate of Registration
- 2007 12 Study & Development Team Certificate of Registration.
12 Venture Company Certificate of Registration.
04 API Certificate of Registration.
- 2006 08 The Corporation was Changed to 'WOOSUNG FLOWTEC Co'
- 2003 08 The Corporation was Changed to 'WOOSUNG STRAINER Co.'
- 2002 05 ISO Certificate of Registration.
- 2000 07 Head Office Moved to Song Jung - dong Factory
- 1998 07 Head Office Moved to Sin Pyung - dong Factory
- 1989 12 Established WOOSUNG PRECISION Co.

FACILITY

Name of Equipment	Standard	Maker	Quantity
TURNING M/C	2000 * 1500	NKK	1
LATHE	JUMBO 1000 * 3000	TUDA SEISAKUSH, CO	1
	HL580 * 2000G	HWACHON	1
	DYNA-1200	KYOKUTO	1
	CLL - 1000	CHUBUKOKI	1
	TIPL - 5 (530 * 1050)	TONGIL	1
BORING M/C	90TL (DIA700 * 1300L)	HAMBURG RIECKERMANN	1
MILLING M/C	TMVH-2	TONGIL	1
RADIAL M/C	JRD 1500	JOGWANG	1
	HOR 915	OGAWA	1
	DA 1300R	DAWOO	1
VERTICAL DRILLING M/C	DUA 560	WOOCHANG	1
	CHKWNG-450	CHKWANG	1
TAP/DRILLING M/C	HTD-025	HEENAM PRESIZON	1
	DIA 13	-	1
PUNCHING M/C	75 TON (NCP-75)	NAGAO	1
	30 TON	AMADA	1
PRESS	0.5 TON	-	1
	5 TON	-	1
HOIST	2.8 TON	BANDO	4
	5.0 TON	BANDO	2
	1.0 TON	BANDO	1
PLATE HOLDER	DP061 (2TON)	EAGLE KOREA	1
	2T-NVG-H (0-30)	NATIO	1
MAGLIFT	KPL-1000	GAESUNG MAGNET	1
CO2 WELDING M/C	CO2/MAG 600	DAEWOO	6
	AUTONEW-T350	CHOWEL	2
TIG WELDING M/C	DUTY-500	PRO-TECH	9
PLASMA CUTTING M/C	PLASMACUT-120A	ARC MAN	3
CUTTING M/C	DIA. 14"	WOOSUNG IND	1
ROUND CUTTING M/C	DIA 1000	-	1
	DIA 1000	-	5
TURN TABLE	TS-100(DIA350)	TAESUNG	2
TABLE LIFT	1600*750*850	-	2
	200 KG/CM ²	-	1
	100 KG/CM ²	-	1
HYDRO TEST M/C	50 KG/CM ²	-	1
	12T	-	1
ROLLING M/C	12T	-	1
FORKLIFT TRUCK	1.5 TON	DAWOO	1
	3.0 TON	DAWOO	1
AIR LESS	PRO-281	DAIHEUNG	6
AIR COMPRESSOR	10 KG/CM2	KYUNGWON	2



World best product with high quality

10

11

WOOSUNG FLOWTEC Co.,Ltd.



CERTIFICATION

MAJOR CUSTOMER



API Q1



ISO 9001/2015



ISO/TS 14001



OHSAS 18001



ACHILLES JQS



KNPC



CE-PED



UL



R&D Dept



PATENT



DESIGN REGISTRATION



DESIGN REGISTRATION



- SAMSUNG ENGINEERING
- SAMSUNG C&T
- HYUNDAI ENGINEERING & CONSTRUCTION
- HYUNDAI ENGINEERING
- SK ENGINEERING & CONSTRUCTION
- GS ENGINEERING & CONSTRUCTION
- DAELIM
- HANWHA ENGINEERING & CONSTRUCTION
- DOOSAN HEAVY INDUSTRIES & CONSTRUCTION
- DOOSAN ENGINEERING & CONSTRUCTION
- HYOSUNG GOODSPRINGS
- LOTTE ENGINEERING & CONSTRUCTION
- POSCO ENGINEERING & CONSTRUCTION
- DAEWOO ENGINEERING & CONSTRUCTION
- GE POWER SYSTEMS KOREA



- HYUNDAI HEAVY INDUSTRIES
- HYUNDAI SAMHO HEAVY INDUSTRIES CO.,LTD
- SAMSUNG HEAVY INDUSTRIES CO.,LTD
- DAEWOO SHIPBUILDING & MARINE ENGINEERING CO.,LTD
- HANJIN HEAVY INDUSTRIES & CONSTRUCTION
- KEPPEL SHIPYARD
- JURONG SHIPYARD

PRODUCT INTRODUCTION

SIMPLEX STRAINER WATER STRAINER FOR CASTING (M/N:WC1)



Specifications

Stress analysis code	ASME Section VIII Division 1.
Connection Flange	JIS B 2210, ANSI B 16.5, DIN, etc.
 Materials	
Body	Carbon Steel, Stainless Steel, Bronze, etc.
Filter	Carbon Steel, Stainless Steel, Monel, Titanium, etc.
Packing	N.B.R, E.P.D.M, P.T.F.E, Viton, etc.
Filter	ø2 - ø12
Mesh	#2 - #100 / 11100 - 140 micron
Lifting	Ring, Yoke
Cover bolting	Yoke, Bolt
Vent / Drain type	Screw, Flange, Valve, etc.
 Coating	
	Tar Free Epoxy, Hot Dipped Galv, etc.
Liquid name	Water, etc.

General

Water strainers for casting are available with bolted or quick release yoked cover. Yoke cover units are ideally suited for applications where frequent clean-out of the filter is expected.

Having a spare, clean filter on hand will greatly reduce the cleaning time, and differential pressure gauges, with alarms, can be supplied to get the maximum on-stream time between cleaning cycles.

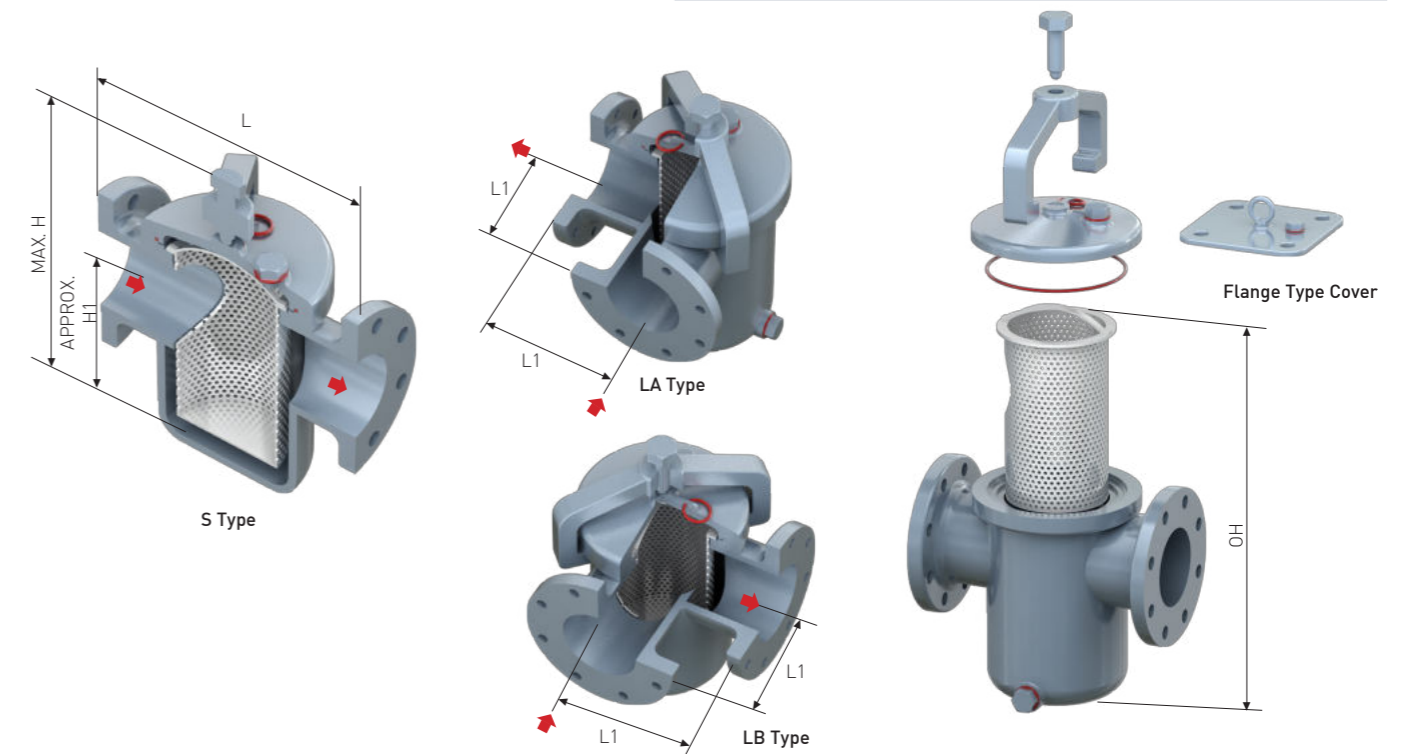

DIMENSION TABLE

Nominal dia	L	L1	H1	H	OH	DRAIN/VENT PLUG	Net Weight(kg)
25A	170	85	75	180	213	M16x2P	6
32A	190	95	85	215	250	M16x2P	8.5
40A	190	95	85	215	250	M16x2P	9
50A	200	100	100	240	291	M16x2P	11
65A	250	125	135	305	376	M20x1.5P	19
80A	270	135	152	340	432	M20x1.5P	24
100A	320	160	185	400	521	M20x1.5P	36

* We can provide bigger size strainers.



SIMPLEX STRAINER
WATER STRAINER FOR CASTING (M/N:WC2)

B
PRODUCT



General

Water strainers for casting are available with bolted or quick release hinge bolted cover. hinge bolted cover units are ideally suited for applications where frequent clean-out of the filter is expected. Having a spare, clean filter on hand will greatly reduce the cleaning time, and differential pressure gauges, with alarms, can be supplied to get the maximum on-stream time between cleaning cycles.

Specifications

Stress analysis code	ASME Section VIII Division 1.
Connection Flange	JIS B 2210, ANSI B 16.5, DIN, etc.
Materials	
Body	Carbon Steel, Stainless Steel, Bronze, etc.
Filter	Carbon Steel, Stainless Steel, Monel, Titanium, etc.
Packing	N.B.R, E.P.D.M, P.T.F.E, Viton, etc.
Filter	ø2 ~ ø12
Mesh	#2 ~ #100 / 11100 ~ 140 micron
Lifting	Lug, Eye bolt, etc.
Cover bolting	Hinge, Stud, Hexagon, etc.
Vent / Drain type	Screw, Flange, Valve, etc.
Coating	Tar Free Epoxy, Hot Dipped Galv, etc.
Liquid name	Water, etc.

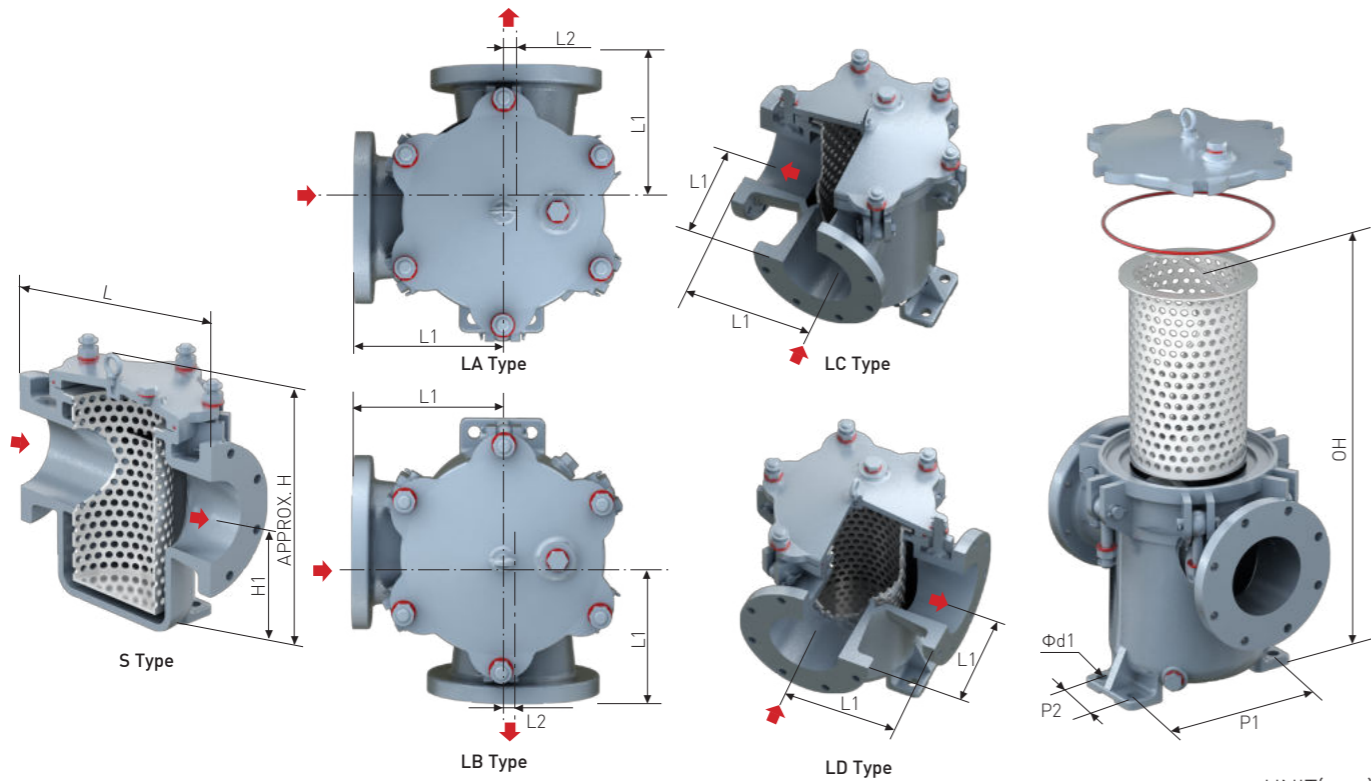

DIMENSION TABLE

Nominal dia	L	L1	L2	H1	H	OH	MOUNTING LEG			DRAIN/VENT PLUG	Net Weight(kg)
							P1	P2	d1		
125A	400	200	30	235	485	672	260	80	Ø19	M24x2P	64
150A	460	230	35	290	575	809	310	90	Ø19	M24x2P	91
200A	550	275	50	350	665	1010	380	100	Ø23	M24x2P	158
250A	680	340	60	450	825	1254	480	140	Ø25	M24x2P	265
300A	760	380	70	515	920	1434	540	160	Ø25	M24x2P	334
350A	820	410	75	575	1030	1634	590	180	Ø25	M24x2P	457
400A	880	440	80	645	1135	1823	650	200	Ø25	M24x2P	615

* We can provide bigger size strainers.

SIMPLEX STRAINER
WATER STRAINER FOR STEEL PLATE (M/N:WS1)

B
PRODUCT



General

Water strainers for steel plate are available with bolted or quick release hinge bolted cover. hinge bolted cover units are ideally suited for applications where frequent clean-out of the filter is expected. Having a spare, clean filter on hand will greatly reduce the cleaning time, and differential pressure gauges, with alarms, can be supplied to get the maximum on-stream time between cleaning cycles.

Specifications

Stress analysis code	ASME Section VIII Division 1.
Connection Flange	JIS B 2210, ANSI B 16.5, DIN, etc.
Materials	
Body	Carbon Steel, Stainless Steel, Bronze, etc.
Filter	Carbon Steel, Stainless Steel, Monel, Titanium, etc.
Packing	N.B.R, E.P.D.M, P.T.F.E, Viton, etc.
Filter	ø2 ~ ø12
Mesh	#2 ~ #100 / 11100 ~ 140 micron
Lifting	Davit, Lug, Handle, etc.
Cover bolting	Hinge, Stud, Hexagon
Vent / Drain type	Screw, Flange, Valve, etc..
Coating	Tar Free Epoxy, N.B.R, P.E, Hot Dipped Galv, etc.
Liquid name	Water, etc.

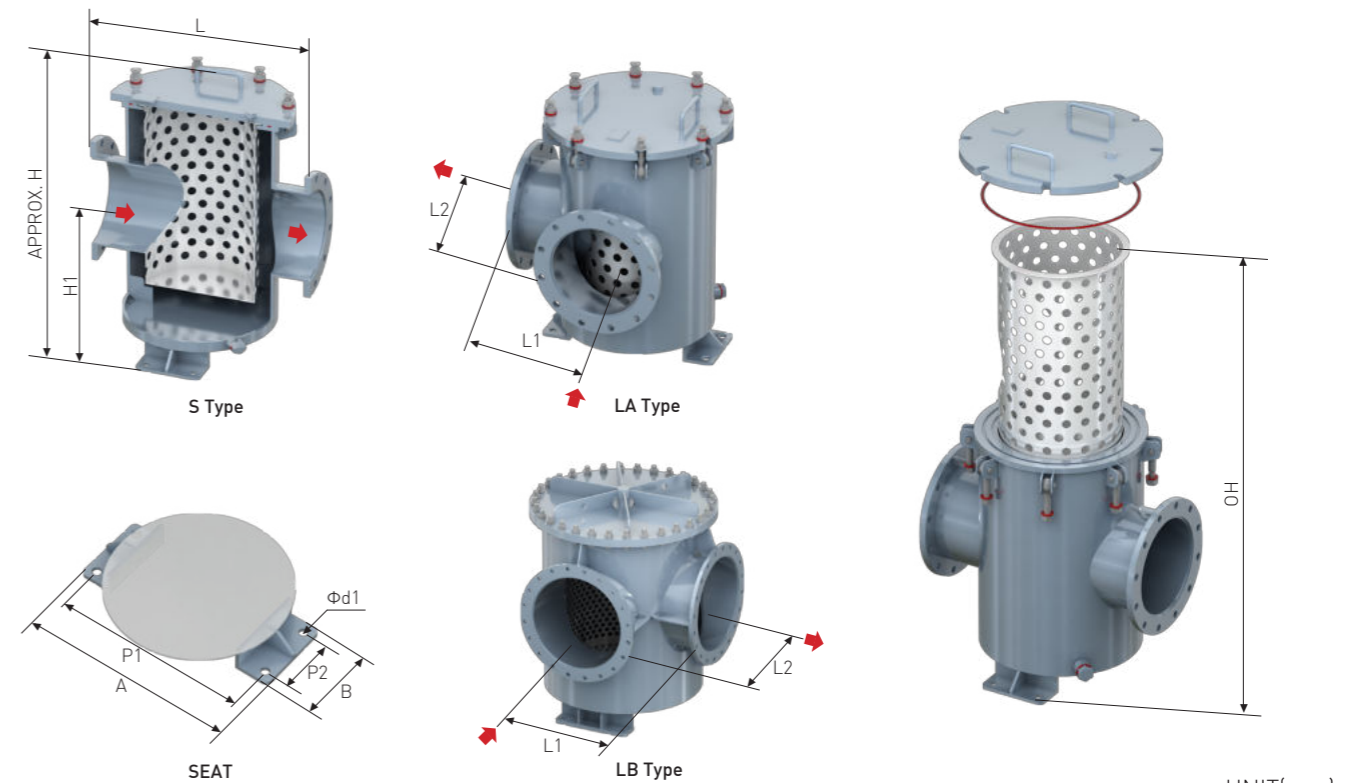

DIMENSION TABLE

Nominal dia	L	L1	L2	H1	H	OH	LEG					DRAIN SIZE	VENT SIZE	Net Weight(kg)	
							A	B	P1	P2	d1			5K	10K
125A	400	200	200	228	472	690	320	140	260	80	19	M20x1.5P		57	60
150A	460	230	230	270	551	830	370	150	310	90	19	M20x1.5P		85	89
200A	550	275	275	310	670	1020	440	160	380	100	23	M20x1.5P		119	122
250A	680	340	340	380	793	1270	540	200	480	140	25	M20x1.5P		218	223
300A	760	380	380	420	900	1450	600	220	540	160	25	M20x1.5P		287	292
350A	820	410	410	470	1019	1700	650	240	590	180	25	M20x1.5P		374	379

* We can provide bigger size strainers.

SIMPLEX STRAINER
WATER STRAINER FOR STEEL PLATE (M/N:WS2)

B
PRODUCT



Specifications

Stress analysis code	ASME Section VIII Division 1.
Connection Flange	JIS B 2210, ANSI B 16.5, DIN, etc.
Materials	
Body	Carbon Steel, Stainless Steel, etc.
Filter	Carbon Steel, Stainless Steel, Monel, Titanium, etc.
Packing	N.B.R, E.P.D.M, P.T.F.E, Viton, etc.
Filter	ø2 ~ ø12
Mesh	#2 ~ #100 / 11100 ~ 140 micron
Lifting	Davit, Lug, etc.
Cover bolting	Bolt, etc.
Vent / Drain type	Screw, Flange, Valve, etc.
Coating	Tar Free Epoxy, N.B.R, P.E, Hot Dipped Galv, etc.
Liquid name	Water, etc.

General

Water strainers for steel plate are available with bolted cover. Bolted cover units are ideally suited for applications where frequent clean-out of the filter is expected. Having a spare, clean filter on hand will greatly reduce the cleaning time, and differential pressure gauges, with alarms, can be supplied to get the maximum on-stream time between cleaning cycles.

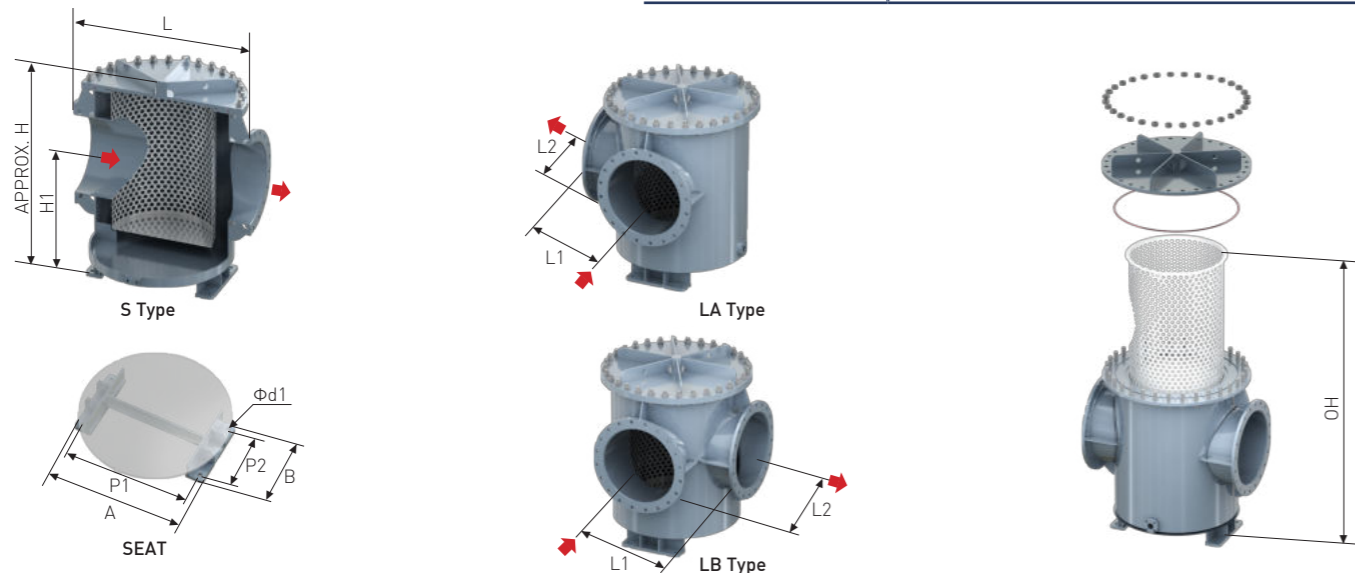

DIMENSION TABLE ※ If customer requirement M.G.P.S, we can installation M.G.P.S in this products. UNIT(mm)

Nominal dia	L	L1	L2	H1	H	OH	LEG					DRAIN SIZE	VENT SIZE	Net Weight(kg)	
							A	B	P1	P2	d1			5K	10K
400A	880	440	520	645	1124	1850	710	260	650	220	25	40A	25A	468	480
450A	1040	520	520	665	1225	1990	740	390	660	310	27	40A	25A	672	687
500A	1130	565	565	720	1325	2150	810	424	730	344	27	40A	25A	797	818
550A	1220	610	610	755	1383	2260	880	460	800	380	27	40A	25A	1004	1030
600A	1310	655	655	800	1455	2390	950	490	870	410	27	40A	25A	1176	1203
650A	1410	705	705	830	1511	2490	1050	550	950	450	33	40A	25A	1418	1451
700A	1500	750	750	865	1568	2600	1130	580	1030	480	33	40A	25A	1515	1557
750A	1600	800	800	890	1608	2660	1145	615	1095	515	33	40A	25A	1811	1860
800A	1700	850	850	905	1635	2710	1270	650	1170	550	33	40A	25A	2028	2078
850A	1800	900	900	955	1725	2910	1320	715	1220	615	33	40A	25A	2278	2331
900A	1900	950	950	1004	1811	3030	1416	718	1316	618	33	40A	25A	2561	2617
1000A	2100	1050	1050	1084	1944	3260	1582	786	1482	686	33	40A	25A	3026	3104

※ We can provide bigger size strainers.

www.woosungflowtec.com

SIMPLEX STRAINER
WATER STRAINER FOR MULTI TYPE (M/N:WM)

B
PRODUCT



Specifications

Stress analysis code	ASME Section VIII Division 1.
Connection Flange	JIS B 2210, ANSI B 16.5, DIN, etc.
Materials	
Body	Carbon Steel, Stainless Steel, Bronze, etc.
Filter	Carbon Steel, Stainless Steel, Monel, Titanium, etc.
Packing	N.B.R, E.P.D.M, P.T.F.E, Viton, Non-Asbestos, etc.
Filter	ø2 ~ ø12
Mesh	N/A
Lifting	Lug, Eye bolt, etc.
Cover bolting	Stud
Vent / Drain type	Screw, Flange, Valve, etc.
Coating	Tar Free Epoxy, N.B.R, P.E, Hot Dipped Galv, etc.
Liquid name	Water, etc.

General

Water strainers for Multi Type are for handling very large volumes of water. They have been in service for 20 years in the electric power industry and the primary metals industry for cleaning cooling water. They are also in wide use in the paper, sewage and water treatment as well as the chemical industries for straining water and to protect equipment. The petroleum industry uses them to remove gums, tars and dirt from oil and oil products.

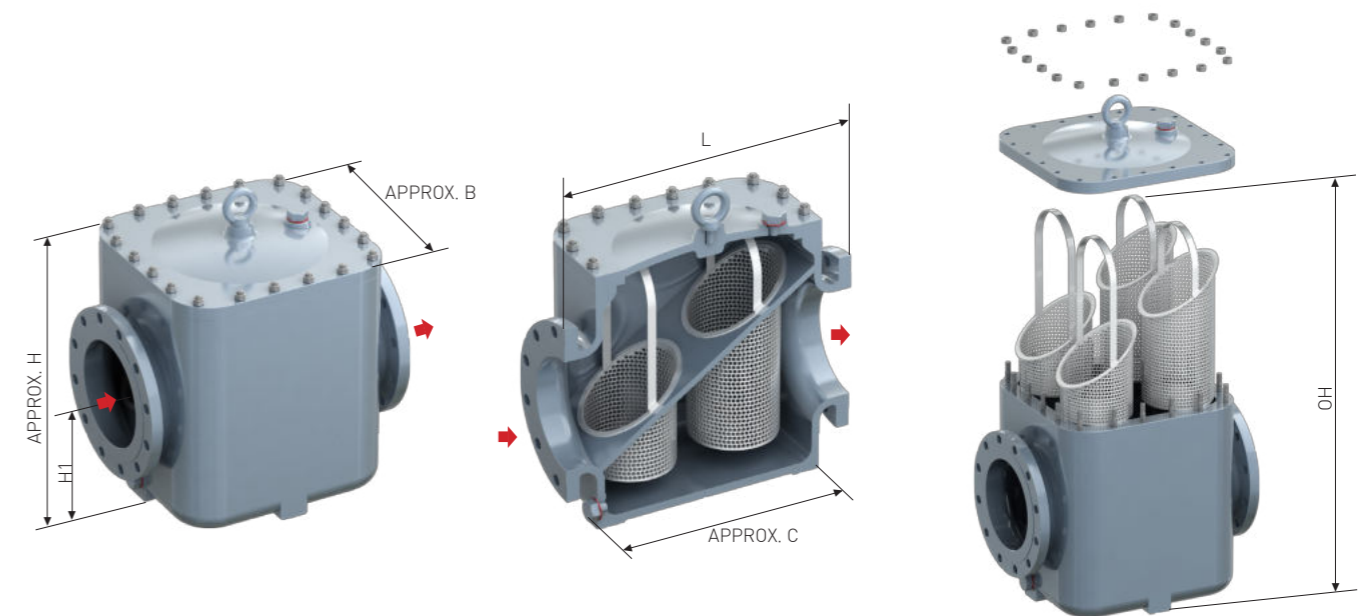

DIMENSION TABLE UNIT(mm)

Nominal dia	L	C	B	H1	H	OH	DRAIN/VENT PLUG	Net Weight(kg)
200A	591	457	470	232	511	965	3/4"	249
250A	664	514	533	289	603	1118	3/4"	332
300A	737	565	578	372	721	1321	3/4"	491
350A	775	626	638	425	794	1524	3/4"	618
400A	851	689	705	486	902	1676	3/4"	795
500A	1137	832	883	724	1175	2235	3/4"	1514
600A	1227	930	978	800	1327	2489	3/4"	2068
750A	1562	1207	1207	1057	1689	3175	3/4"	4036
900A	1562	1207	1207	1057	1689	3175	3/4"	4409

※ We can provide bigger size strainers.

www.woosungflowtec.com

SIMPLEX STRAINER
WATER STRAINER FOR TRAPEZOID TYPE (M/N:WT)



General

Water Strainers for Trapezoid type are available cover where frequent clean-out of the filter is expected. Having a spare, clean filter on hand will greatly reduce the cleaning time, and differential pressure gauges, with alarms, can be supplied to get the maximum on-stream time between cleaning cycles.

Specifications

Stress analysis code	ASME Section VIII Division 1.
Connection Flange	JIS B 2210, ANSI B 16.5, DIN, etc.
Materials	
Body	Carbon Steel, Stainless Steel, etc.
Filter	Carbon Steel, Stainless Steel, Monel, Titanium, etc.
Packing	N.B.R, E.P.D.M, P.T.F.E, Viton, etc.
Filter	ø2 ~ ø12
Mesh	N/A
Lifting	Handle, Davit, Lug, etc.
Cover bolting	Stud, Hexagon, etc.
Vent / Drain type	Screw, Flange, Valve, etc.
Coating	Tar Free Epoxy, N.B.R, P.E, Hot Dipped Galv, etc.
Liquid name	Water, etc.

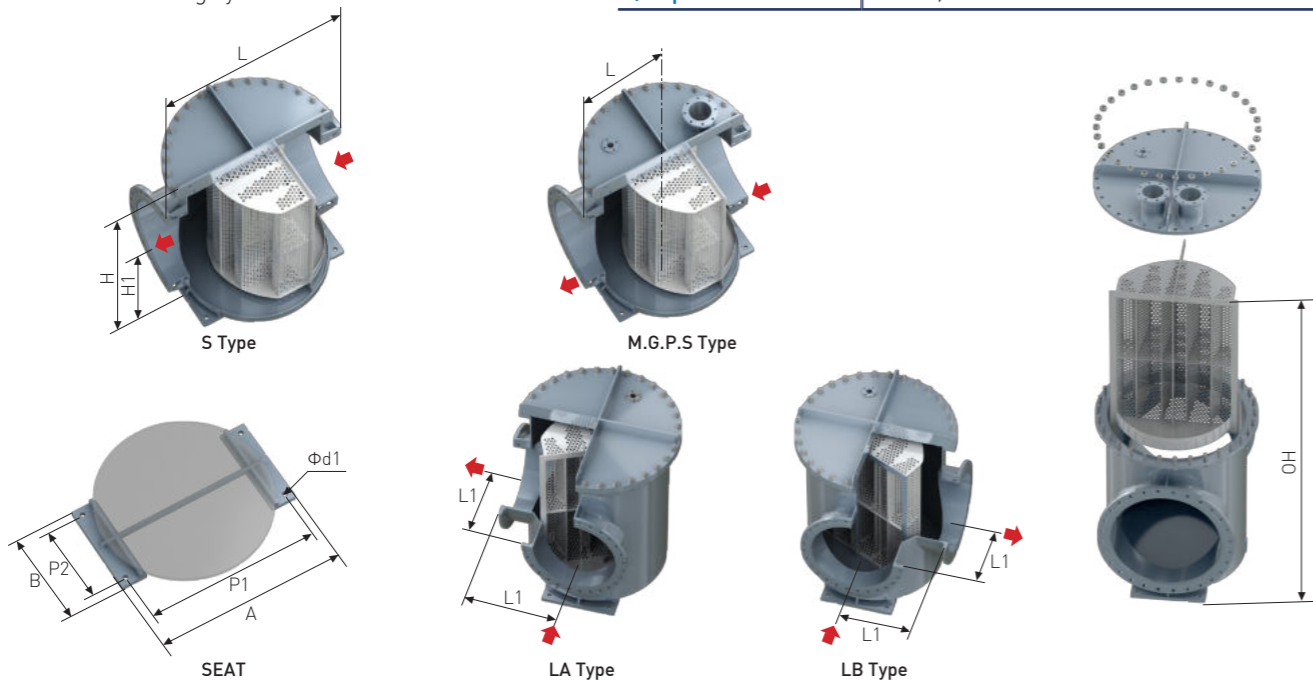

DIMENSION TABLE

Nominal dia	L1		L	H1	H	P1	P2	d1	OH	Net Weight(kg)	
	S	LA/LB								5K	10K
	450A	410								475	730
500A	445	510	820	470	894	640	300	27	1650	532	553
550A	495	560	890	480	926	700	330	27	1715	647	673
600A	535	600	990	520	985	780	360	33	1830	782	808
650A	575	640	1070	550	1045	850	400	33	1950	904	937
700A	610	680	1150	585	1105	910	430	33	2070	1104	1147
750A	650	720	1220	600	1180	980	460	33	2220	1268	1317
800A	685	755	1300	605	1185	1030	480	33	2430	1428	1589
900A	740	890	1480	720	1440	1130	510	33	2740	1699	1880
1000A	830	970	1660	790	1577	1270	560	39	3015	2109	2187

* We can provide bigger size strainers.

SIMPLEX STRAINER
OIL STRAINER FOR CASTING (M/N:OC)



General

Oil strainers for Casting are available with bolted or quick release yoked cover. Yoke cover units are ideally suited for applications where frequent clean-out of the filter is expected. Having a spare, clean filter on hand will greatly reduce the cleaning time, and differential pressure gauges, with alarms, can be supplied to get the maximum on-stream time between cleaning cycles.

Specifications

Stress analysis code	ASME Section VIII Division 1.
Connection Flange	JIS B 2210, ANSI B 16.5, DIN, etc.
Materials	
Body	Carbon Steel, Stainless Steel, Bronze, etc.
Filter	Carbon Steel, Stainless Steel, Monel, Titanium, etc.
Packing	N.B.R, E.P.D.M, P.T.F.E, Viton, etc.
Filter	ø2 ~ ø12
Mesh	#2 ~ #400 / 11100 ~ 35 micron
Lifting	Yoke, Ring, Eye bolt
Cover bolting	Yoke, Stud bolt
Vent / Drain type	Screw, Flange, Valve, etc.
Coating	Tar Free Epoxy, N.B.R, P.E, Hot Dipped Galv, etc.
Liquid name	Oil, Oily Water, etc.

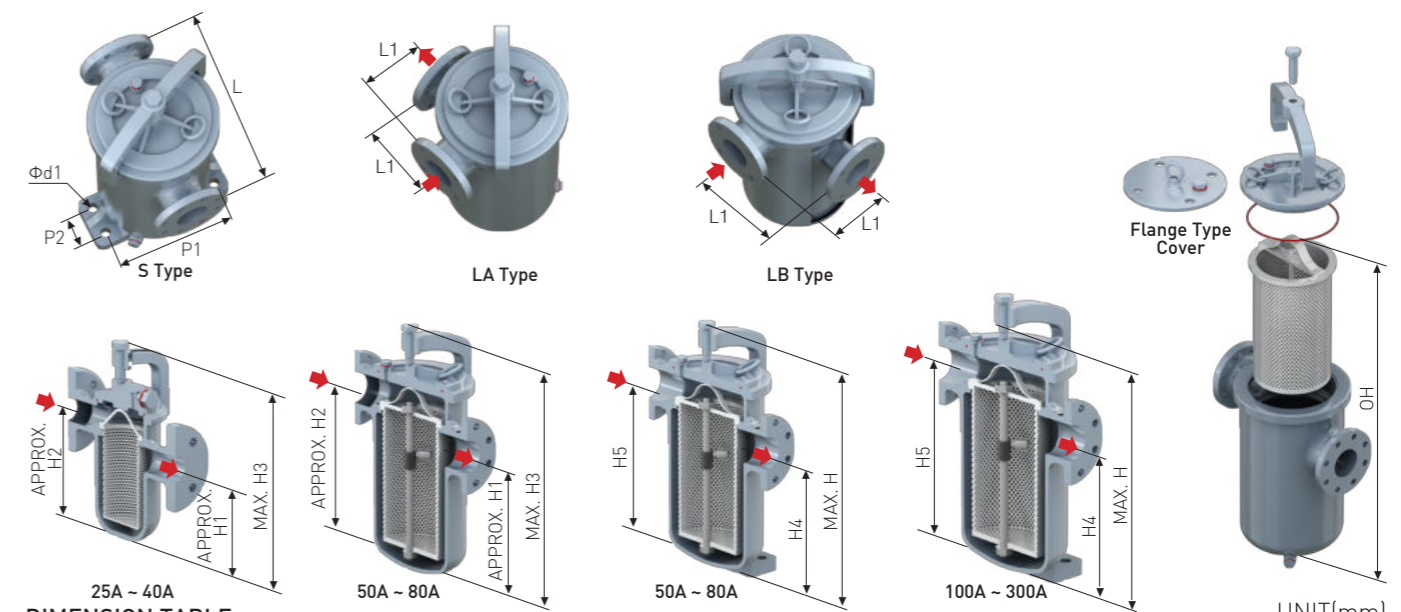

DIMENSION TABLE

Nominal dia	L	L1	H1	H2	H3	H4	H5	H	OH	P1	P2	d1	DRAIN/VENT PLUG	Net Weight (kg)
25A	190	95	91	123	240	-	-	-	281	-	-	-	M20x1.5P	7
32A	260	130	145	188	315	-	-	-	411	-	-	-	M20x1.5P	15
40A	260	130	145	188	315	-	-	-	411	-	-	-	M20x1.5P	15
50A	280	140	187	237	374	208	258	395	521[542]	-	-	-	M20x1.5P	26
65A	340	170	248	315	470	273	340	495	684[709]	-	-	-	M20x1.5P	44
80A	370	185	258	331	500	283	356	525	743[768]	-	-	-	M20x1.5P	51
100A	420	210	-	-	-	315	430	630	893	315	90	19	M20x1.5P	80
125A	450	225	-	-	-	373	482	745	1045	345	90	23	M24x2P	107
150A	470	235	-	-	-	410	540	825	1189	370	90	23	M24x2P	154
200A	570	285	-	-	-	475	630	970	1413	435	120	25	M24x2P	243
250A	700	350	-	-	-	529	729	1140	1683	520	150	27	M24x2P	262
300A	800	400	-	-	-	542	772	1220	1810	545	160	27	M24x2P	453

* We can provide bigger size strainers.

SIMPLEX STRAINER
OIL STRAINER FOR STEEL PLATE (M/N:OS)

B
PRODUCT



General

Oil Strainers for Steel Plate (here in after referred to as "Oil strainer") used on the suction side of main lubricating oil pumps in ships.

Specifications

Stress analysis code	ASME Section VIII Division 1.
Connection Flange	JIS B 2210, ANSI B 16.5, DIN, etc.
Materials	
Body	Carbon Steel, Stainless Steel, etc.
Filter	Carbon Steel, Stainless Steel, Monel, Titanium, etc.
Packing	N.B.R, E.P.D.M, P.T.F.E, Viton, etc.
Filter	ø2 ~ ø12
Mesh	#2 ~ #400 / 11100 ~ 35 micron
Lifting	Handle, Davit, Lug, etc.
Cover bolting	Hinge, Stud, Hexagon, etc.
Vent / Drain type	Screw, Flange, Valve, etc.
Coating	Tar Free Epoxy, N.B.R, P.E, Hot Dipped Galv, etc.
Liquid name	Oil, Water, etc.

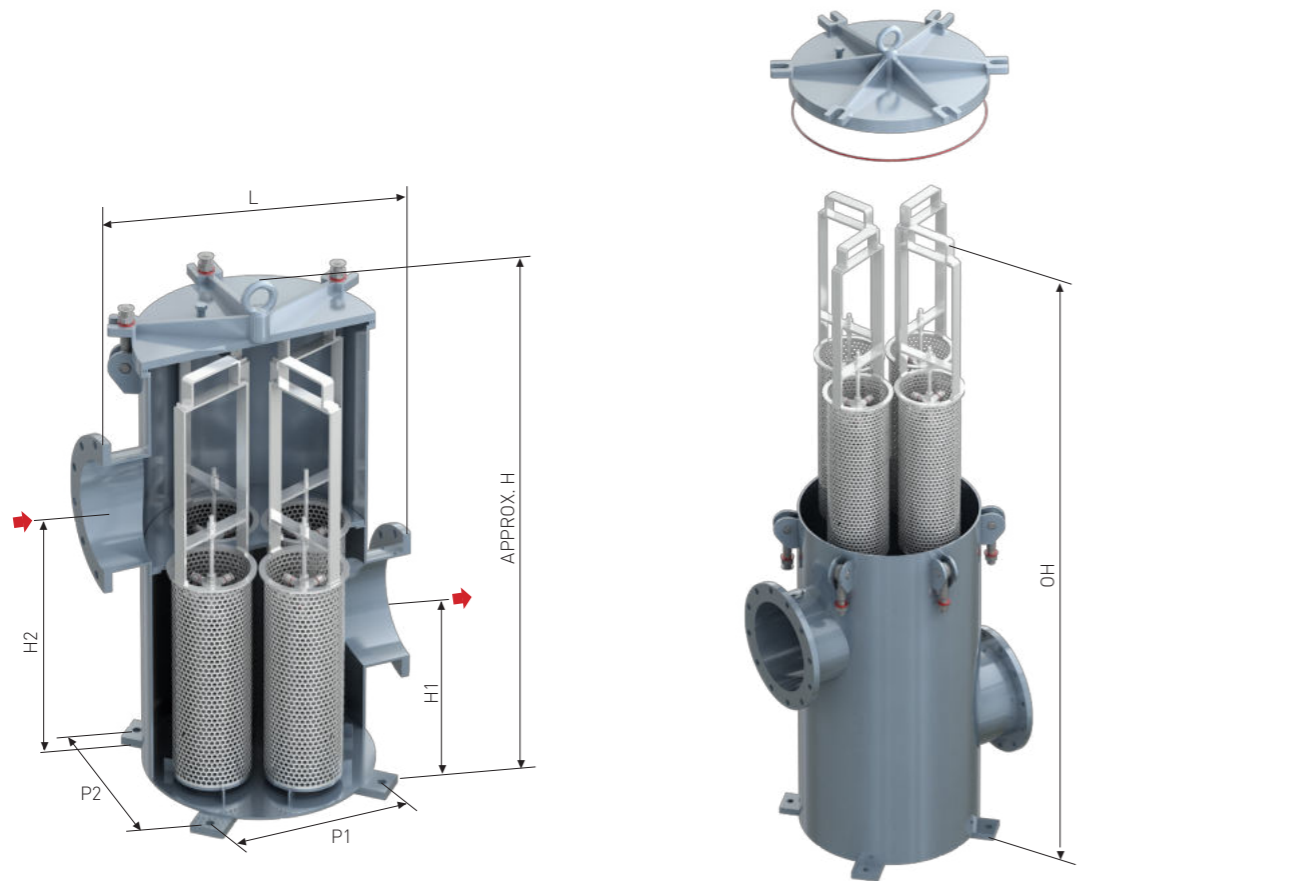

DIMENSION TABLE

Nominal dia	L	H1	H2	H	P1	P2	OH	Net Weight (kg)	
								150LB	300LB
350A	880	390	790	1210	530	530	1995	547	
400A	880	515	965	1415	530	530	2405	613	

* We can provide bigger size strainers.

www.woosungflowtec.com

SIMPLEX STRAINER
BUCKET STRAINER FOR CASTING (M/N:BC)

B
PRODUCT



General

Bucket Strainers for casting are mainly installed in horizontal piping. Since the bucket strainer elements housed in the bodies can be taken out from the tops, the debris caught by the elements can be taken outside easily. The design of bucket strainers can be arranged to suit lager piping .

Specifications

Stress analysis code	ASME Section VIII Division 1.
Connection Flange	JIS B 2210, ANSI B 16.5, DIN, etc.
Flange Rating	150LB, 300LB, 400LB, 600LB, 900LB, 1500LB, 2500LB
Materials	
Body	Carbon Steel, Stainless Steel, etc.
Filter	Carbon Steel, Stainless Steel, Monel, Titanium, etc.
Packing	N.B.R, E.P.D.M, P.T.F.E, Viton, Non-Asbestos, S.W.G, etc.
Filter	ø2 ~ ø12
Mesh	#2 ~ #400 / 11100 ~ 35 micron
Lifting	Handle, Davit, Lug, etc.
Cover bolting	Stud, Hexagon, etc.
Vent / Drain type	Screw, Flange, Valve, etc.
Coating	Tar Free Epoxy, N.B.R, P.E, Hot Dipped Galv, etc.
Liquid name	Oil, Water, etc.

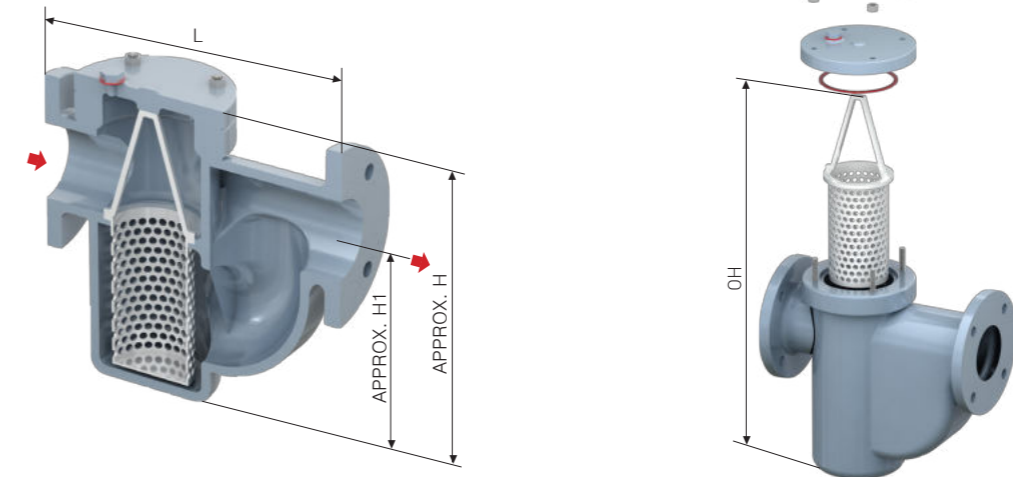

DIMENSION TABLE

Nominal dia	L		H1	H		OH	DRAIN	VENT	Net Weight(kg)	
	150LB	300LB		150LB	300LB				150LB	300LB
25A	200	210	120	205	205	300	1/2"	1/2"	11	15
32A	225	235	120	208	208	370	1/2"	1/2"	13	17
40A	225	235	120	222	222	370	1/2"	1/2"	14	19
50A	245	255	160	253	253	430	1/2"	1/2"	18	24
65A	280	290	195	280	280	490	1/2"	1/2"	25	30
80A	300	310	210	330	330	560	1/2"	1/2"	33	45
100A	355	370	250	390	390	690	1/2"	1/2"	50	60
125A	445	495	317	467	467	878	1/2"	1/2"	86	100
150A	505	540	400	643	643	1062	1/2"	1/2"	116	145
200A	665	700	520	854	854	1350	3/4"	3/4"	170	195
250A	710	755	637	996	996	1715	3/4"	3/4"	240	300
300A	850	885	778	1185	1185	2067	3/4"	3/4"	550	580

* We can provide bigger size strainers.

www.woosungflowtec.com

SIMPLEX STRAINER
BUCKET STRAINER FOR STEEL PLATE (M/N:BS1)

B
PRODUCT



General

Bucket Strainers for steel plate are mainly installed in horizontal piping. Since the bucket strainer elements housed in the bodies can be taken out from the tops, the debris caught by the elements can be taken outside easily. The design of bucket strainers can be arranged to suit larger piping.

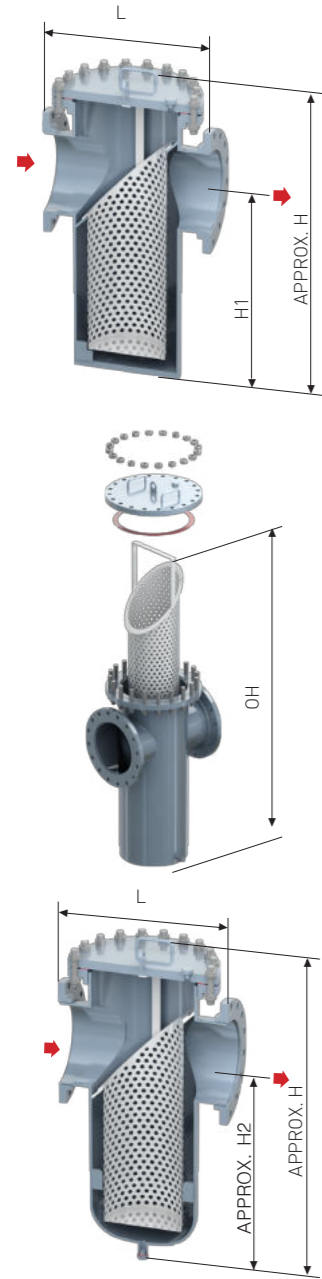

Specifications

Stress analysis code	ASME Section VIII Division 1.
Connection Flange	JIS B 2210, ANSI B 16.5, DIN, etc.
Flange Rating	150LB, 300LB, 400LB, 600LB, 900LB, 1500LB, 2500LB
Materials	
Body	Carbon Steel, Stainless Steel, etc.
Filter	Carbon Steel, Stainless Steel, Monel, Titanium, etc.
Packing	N.B.R, E.P.D.M, P.T.F.E, Viton, Non-Asbestos, S.W.G, etc.
Filter	ø2 ~ ø12
Mesh	#2 ~ #400 / 11100 ~ 35 micron
Lifting	Handle, Davit, Lug, etc.
Cover bolting	Stud, Hexagon, etc.
Vent / Drain type	Screw, Flange, Valve, etc.
Coating	Tar Free Epoxy, N.B.R, P.E, Hot Dipped Galv, etc.
Liquid name	Oil, Water, etc.

DIMENSION TABLE

UNIT(mm)

Nominal dia	L		H1	H		OH		DRAIN	VENT	Net Weight(kg)		H1	H2	
	150LB	300LB		150LB	300LB	150LB	300LB			150LB	300LB			
125A	5"	500	538	495	791	852	1163	1250	½"	½"	116	261	360	495
150A	6"	510	540	555	861	930	1303	1410	½"	½"	126	279	420	555
200A	8"	560	600	680	1028	1107	1610	1735	½"	½"	190	323	520	680
250A	10"	610	720	758	1149	1218	1835	1935	½"	½"	253	406	600	758
300A	12"	700	780	906	1348	1428	2214	2214	1"	1"	351	562	740	906
350A	14"	750	820	1018	1493	1584	2475	2615	1"	1"	431	706	830	1018
400A	16"	800	940	1163	1672	1742	2797	2900	1"	1"	560	909	960	1163
450A	18"	900	1040	1329	1880	1980	3185	3340	1"	1"	684	1099	1250	1329
500A	20"	1000	1100	1482	2157	2229	3535	3635	1"	1"	848	1629	1410	1482
550A	22"	1100	1200	1632	2368	2484	3915	4115	1"	1"	1151	1726	1560	1632
600A	24"	1150	1250	1782	2552	2670	4275	4475	1"	1"	1359	2095	1710	1782
650A	26"	1200	1340	1850	2735	2855	4635	4835	1"	1"	1631	2355	1780	1850
700A	28"	1300	1420	2150	2871	3010	4895	5135	1"	1"	1977	2792	2080	2150
750A	30"	1400	1520	2400	2971	3131	5075	5355	1"	1"	2437	3273	2330	2400
800A	32"	1500	1620	2524	3160	3276	5413	5610	1"	1"	2785	3409	2455	2524
900A	36"	1650	1670	2697	3535	3657	6153	6353	1"	1"	3497	4216	2630	2697
1000A	40"	1750	1750	2805	3890	4015	6811	7011	1"	1"	4268	4640	2735	2805

* We can provide bigger size strainers.

SIMPLEX STRAINER
BUCKET STRAINER FOR STEEL PLATE (M/N:BS2)

B
PRODUCT



General

Bucket Strainers for steel plate are mainly installed in horizontal piping. Since the bucket strainer elements housed in the bodies can be taken out from the tops, the debris caught by the elements can be taken outside easily. The design of bucket strainers can be arranged to suit larger piping.

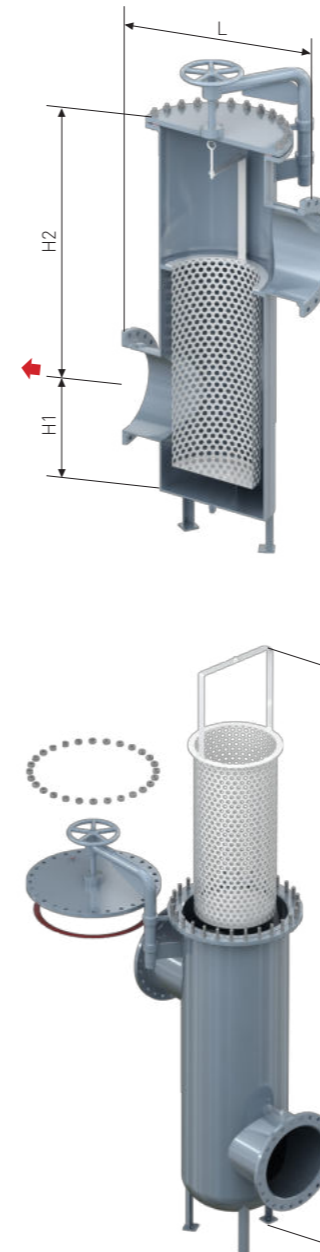

Specifications

Stress analysis code	ASME Section VIII Division 1.
Connection Flange	JIS B 2210, ANSI B 16.5, DIN, etc.
Flange Rating	150LB, 300LB, 400LB, 600LB, 900LB, 1500LB, 2500LB
Materials	
Body	Carbon Steel, Stainless Steel, etc.
Filter	Carbon Steel, Stainless Steel, Monel, Titanium, etc.
Packing	N.B.R, E.P.D.M, P.T.F.E, Viton, Non-Asbestos, S.W.G, etc.
Filter	ø2 ~ ø12
Mesh	#2 ~ #400 / 11100 ~ 35 micron
Lifting	Handle, Davit, Lug, etc.
Cover bolting	Stud, Hexagon, etc.
Vent / Drain type	Screw, Flange, Valve, etc.
Coating	Tar Free Epoxy, N.B.R, P.E, Hot Dipped Galv, etc.
Liquid name	Oil, Water, etc.

DIMENSION TABLE

UNIT(mm)

Nominal dia	L		H1	H2		OH	DRAIN	VENT	Net Weight(kg)	
	150LB	300LB		150LB	300LB				150LB	300LB
125A	500	580	495	791	802	1163	½"	½"	110	190
150A	510	600	555	861	872	1303	½"	½"	130	210
200A	560	680	681	1028	1041	1610	½"	½"	200	310
250A	610	760	759	1150	1168	1832	½"	½"	240	390
300A	700	840	906	1348	1367	2214	½"	½"	360	570
350A	750	900	1019	1494	1513	2472	1"	1"	460	750
400A	800	980	1164	1672	1693	2797	1"	1"	570	940
450A	900	1050	1329	1881	1902	3182	1"	1"	770	1280
500A	1000	1100	1482	2150	2179	3535	1"	1"	1050	1650
550A	1100	1131	1632	2368	2389	3915	1"	1"	1220	1960
600A	1150	1182	1782	2552	2574	4275	1"	1"	1490	2420
650A	1200	1326	1932	2735	2746	4635	1"	1"	1680	3050
700A	1300	1444	2032	2871	2885	4895	1"	1"	1740	3360
750A	1400	1546	2082	2971	2988	5075	1"	1"	2180	3685
800A	1500	1655	2220	3160	3178	5413	1"	1"	2460	3993
900A	1650	1818	2520	3535	3550	6153	1"	1"	3190	4340
1000A	1750	1904	2808	3890	3914	6811	1"	1"	3970	5860

* We can provide bigger size strainers.

DUPLEX STRAINERS
COCK VALVE H TYPE (M/N:DC)

B
PRODUCT



General

Cock Valve H Type is a simple, economical, and trouble free design... time tested in applications around the world over many years. This type of strainer is actually a high quality, pressure rated plug valve with integral straining filters. Switching the flow from one filter to the other is accomplished by moving the operating handle through a 90 degree arc. The design is such that is impossible for this operation to stop the flow because of the unique port design in the diverter plug. The plug is automatically positioned each time in exactly the right spot by integral stops.

Specifications

Stress analysis code	ASME Section VIII Division 1.
Connection Flange	JIS B 2210, ANSI B 16.5, DIN, etc.
Materials	
Body	Carbon Steel, Stainless Steel, Bronze, etc.
Filter	Carbon Steel, Stainless Steel, Monel, Titanium, etc.
Packing	N.B.R, E.P.D.M, P.T.F.E, Viton, etc.
Filter	ø2 ~ ø12
Mesh	#2 ~ #400 / 11100 ~ 35 micron
Lifting	Yoke, Lug, etc.
Cover bolting	Yoke, Bolt, etc.
Vent / Drain type	Screw, Flange, Valve, etc.
Coating	Tar Free Epoxy, Hot Dipped Galv, etc.
Liquid name	Oil, Water, etc.

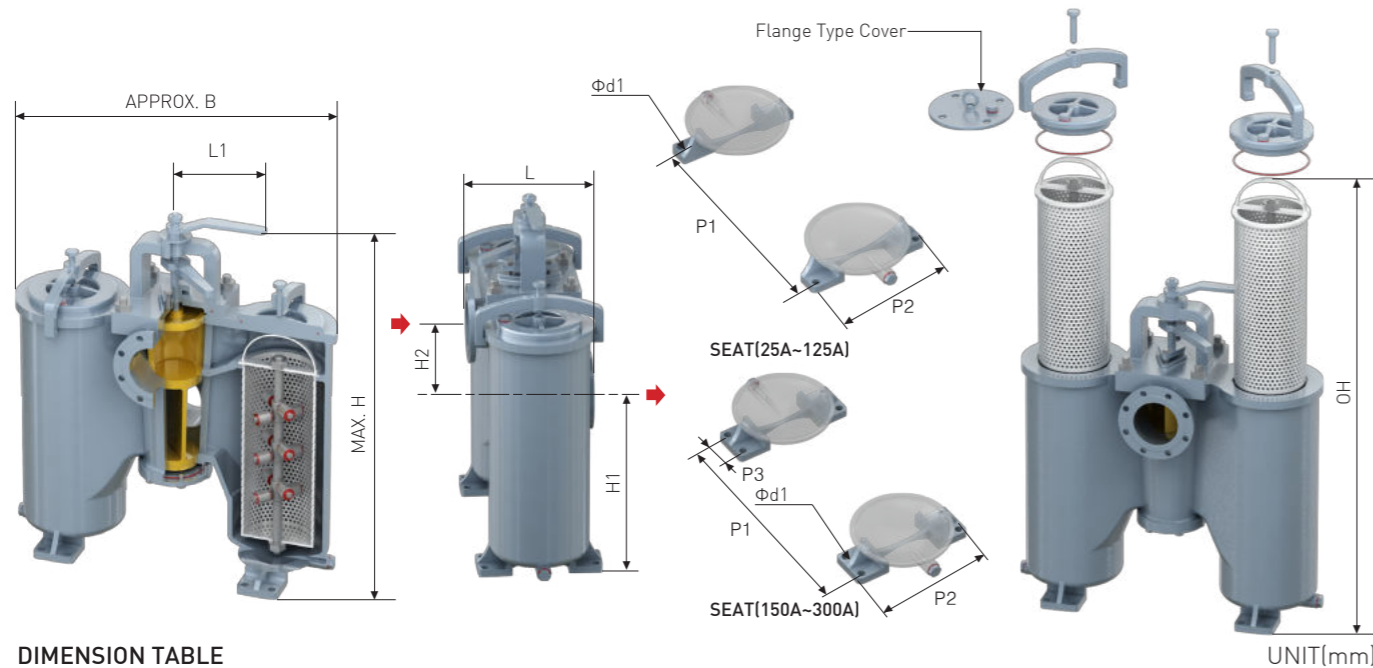

DIMENSION TABLE

Nominal dia	L1	B	L	H1	H2	H	P1	P2	P3	d1	OH	DRAIN/VENT PLUG	Net Weight (kg)
25A	150	315	165	130	40	410	220	100	-	12	370	M20x1.5P	36
32A	150	380	195	165	55	490	290	140	-	15	490	M20x1.5P	50
40A	150	380	195	165	55	490	290	140	-	15	490	M20x1.5P	50
50A	150	415	180	219	66	516	302	150	-	15	610	M20x1.5P	60
65A	180	514	215	273	85	661	375	185	-	19	745	M20x1.5P	87
80A	210	600	245	312	102	685	440	215	-	19	884	M20x1.5P	126
100A	250	718	285	371	126	816	524	255	-	23	1052	M24x2P	191
125A	300	852	330	431	157	952	620	305	-	23	1255	M24x2P	321
150A	320	1046	410	516	201	1299	760	365	80	23	1538	M24x2P	566
200A	380	1250	490	645	245	1520	920	430	100	27	1940	M24x2P	906
250A	380	1600	570	695	370	1783	1100	495	120	33	2466	M24x2P	1555
300A	380	1900	700	695	370	1940	1425	540	120	33	2780	M24x2P	1986

* We can provide bigger size strainers.

DUPLEX STRAINERS
COCK VALVE HS TYPE (M/N:DC2)

B
PRODUCT



General

Cock Valve H Type is a simple, economical, and trouble free design... time tested in applications around the world over many years. This type of strainer is actually a high quality, pressure rated plug valve with integral straining filters. Switching the flow from one filter to the other is accomplished by moving the operating handle through a 90 degree arc. The design is such that is impossible for this operation to stop the flow because of the unique port design in the diverter plug. The plug is automatically positioned each time in exactly the right spot by integral stops.

Specifications

Stress analysis code	ASME Section VIII Division 1.
Connection Flange	JIS B 2210, ANSI B 16.5, DIN, etc.
Materials	
Body	Carbon Steel, Stainless Steel, Bronze, etc.
Filter	Carbon Steel, Stainless Steel, Monel, Titanium, etc.
Packing	N.B.R, E.P.D.M, P.T.F.E, Viton, etc.
Filter	ø2 ~ ø12
Mesh	#2 ~ #400 / 11100 ~ 35 micron
Lifting	Yoke, Lug, etc.
Cover bolting	Yoke, Bolt, etc.
Vent / Drain type	Screw, Flange, Valve, etc.
Coating	Tar Free Epoxy, Hot Dipped Galv, etc.
Liquid name	Oil, Water, etc.

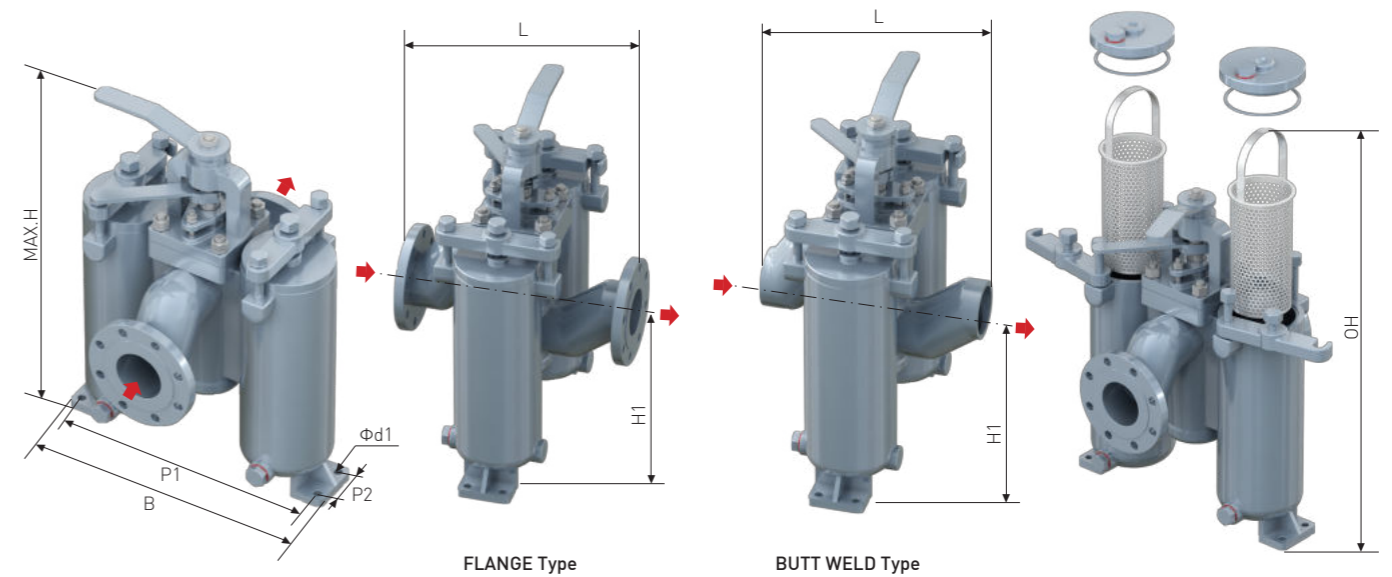

DIMENSION TABLE

Nominal dia	B	L	H1	H	P1	P2	d1	OH	DRAIN/VENT PLUG	Net Weight (kg)
25A	268	175	127	407	236	50	12	510	M20x1.5P	36
32A	330	175	173	453	298	60	15	530	M20x1.5P	50
40A	330	238	173	453	298	60	15	530	M20x1.5P	50
50A	458	300	220	500	430	60	15	538	M20x1.5P	60
65A	559	343	225	546	527	64	16	633	M20x1.5P	87
80A	559	343	225	546	527	64	16	633	M20x1.5P	126
100A	584	406	336	765	546	76	16	919	M20x1.5P	191
125A	899	467	375	845	849	76	23	1148	M24x2P	321
150A	910	570	550	1133	860	153	23	1345	M24x2P	566
200A	1310	635	586	1286	1250	153	27	1706	M24x2P	906

* We can provide bigger size strainers.

DUPLEX STRAINERS
COCK VALVE PC TYPE (M/N:DC3)

B
PRODUCT

General

Cock Valve PC Type is a simple, economical, and trouble free design... time tested in applications around the world over many years. This type of strainer is actually a high quality, pressure rated plug valve with integral straining filters. Switching the flow from one filter to the other is accomplished by moving the operating handle through a 90 degree arc. The design is such that is impossible for this operation to stop the flow because of the unique port design in the diverter plug. The plug is automatically positioned each time in exactly the right spot by integral stops.



Specifications

Stress analysis code	ASME Section VIII Division 1.
Connection Flange	JIS B 2210, ANSI B 16.5, DIN, etc.
Materials	
Body	Carbon Steel, Stainless Steel, Bronze, etc.
Filter	Carbon Steel, Stainless Steel, Monel, Titanium, etc.
Packing	N.B.R, E.P.D.M, P.T.F.E, Viton, etc.
Filter	ø2 ~ ø12
Mesh	#2 ~ #400 / 11100 ~ 35 micron
Lifting	Yoke, Lug
Cover bolting	Yoke
Vent / Drain type	Screw, Flange, Valve, etc.
Coating	Tar Free Epoxy, Hot Dipped Galv, etc.
Liquid name	Oil, Water, etc.

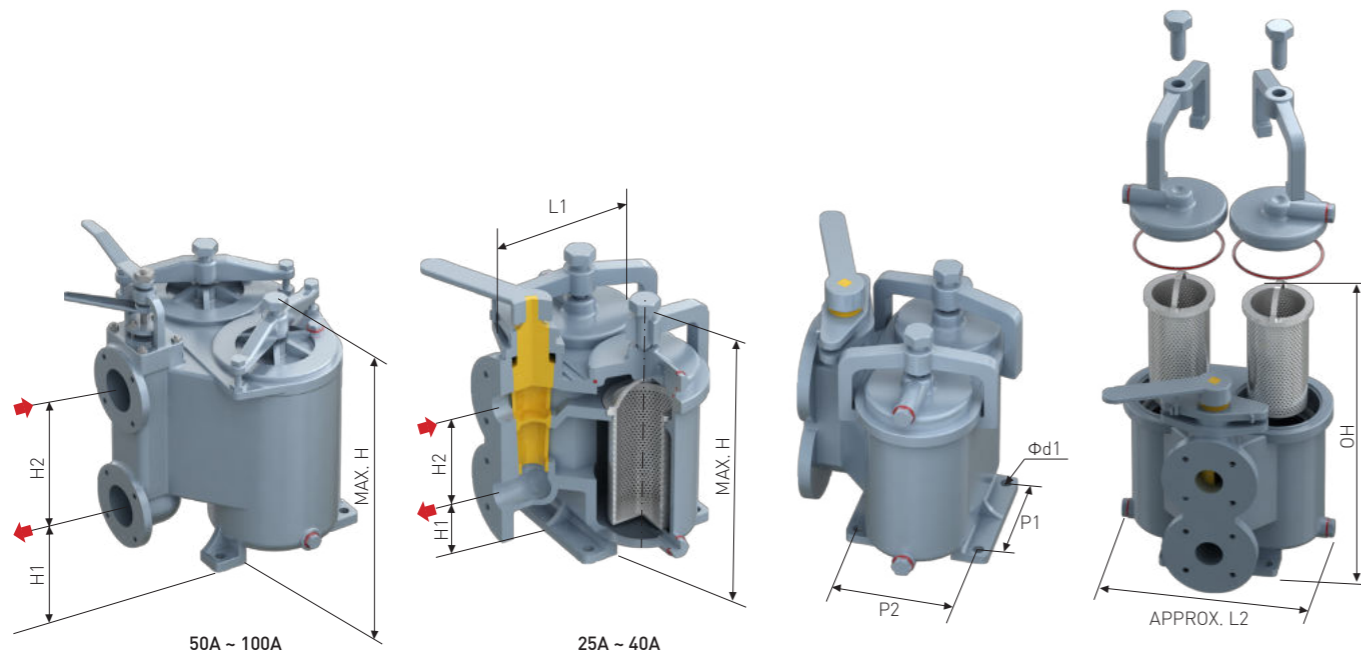

DIMENSION TABLE

Nominal dia	L1	L2	H1	H2	H	P1	P2	d1	OH	DRAIN	VENT	Net Weight (kg)
25A	167	196	53	80	235	128	100	12	265	M20x1.5P	M20x1.5P	36
32A	241	280	78	125	355	176	152	15	350	M20x1.5P	M20x1.5P	50
40A	241	280	78	125	355	176	152	15	406	M20x1.5P	M20x1.5P	50
50A	317	354	120	145	495	235	200	15	530	M20x1.5P	M20x1.5P	72
65A	397	436	123	195	580	280	260	15	635	M20x1.5P	M20x1.5P	114
80A	445	501	150	320	670	320	290	15	740	M20x1.5P	M20x1.5P	159
100A	525	585	115	310	760	360	340	15	850	M20x1.5P	M20x1.5P	244

* We can provide bigger size strainers.

www.woosungflowtec.com

DUPLEX STRAINERS
BUTTERFLY VALVE Y TYPE (M/N:DC4)

B
PRODUCT

General

Butterfly Valve Y Type is a new design with several interesting features and advantages. Flow is switched from one basket to the other by a pair of synchronized butterfly valves. This gives a straight flow pattern with no sudden changes in direction. Result - low pressure loss. A 10" strainer of this type, for example, can handle 2,000 GPM of water with a pressure drop of only 2 psi. This is the strainer to use when high flow and low pressure loss are critical.



Specifications

Stress analysis code	ASME Section VIII Division 1.
Connection Flange	JIS B 2210, ANSI B 16.5, DIN, etc.
Materials	
Body	Carbon Steel, Stainless Steel, Bronze, etc.
Filter	Carbon Steel, Stainless Steel, Monel, Titanium, etc.
Packing	N.B.R, E.P.D.M, P.T.F.E, Viton, Non-Asbestos, etc.
Filter	ø2 ~ ø12
Mesh	N/A
Lifting	Lug, etc.
Cover bolting	Hinge, etc.
Vent / Drain type	Screw, Flange, Valve, etc.
Coating	Tar Free Epoxy, N.B.R, Hot Dipped Galv, etc.
Liquid name	Water, etc.

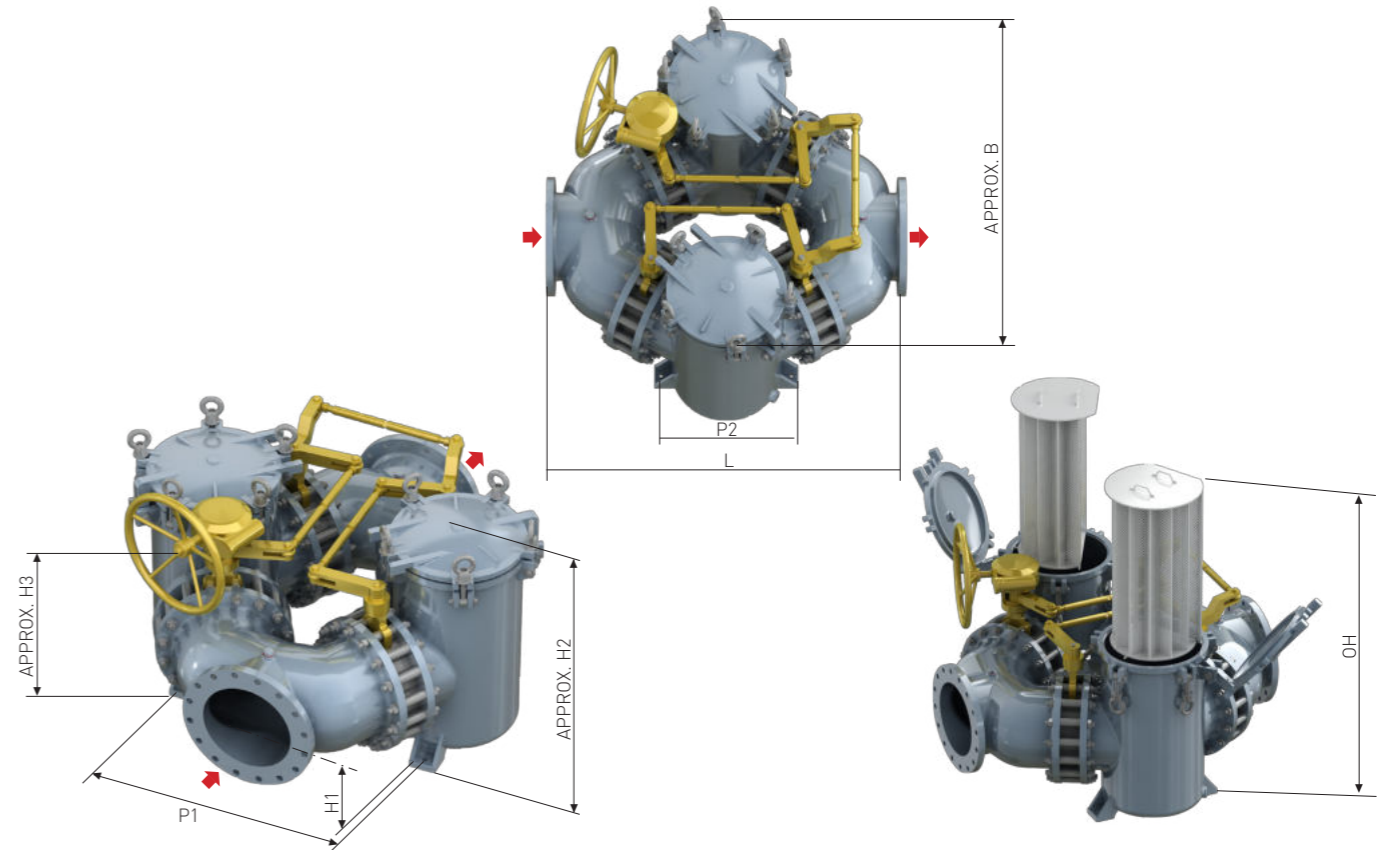

DIMENSION TABLE

Nominal dia	L	B	H1	H2	H3	P1	P2	OH	DRAIN	VENT	Net Weight(kg)
250A	1143	1296	310	737	770	813	483	1245	1 1/2"	1/4"	910
300A	1575	1626	427	966	930	1041	584	1677	1 1/2"	1/4"	1508
350A	1829	1931	478	1131	1138	1219	686	1956	1 1/2"	1/4"	2447
400A	1829	1931	478	1131	1138	1219	686	1956	1 1/2"	1/4"	3147
450A	1829	1931	478	1131	1138	1219	686	1956	1 1/2"	1/4"	3847

* We can provide bigger size strainers.

www.woosungflowtec.com

B
PRODUCT

DUPLEX STRAINERS
MULTI TYPE (M/N:DC5)



General

Multi Type is for handling very large volumes of water. They have been in service for 20 years in the electric power industry and the primary metals industry for cleaning cooling water. They are also in wide use in the paper, sewage and water treatment as well as the chemical industries for straining water and to protect equipment. The petroleum industry uses them to remove gums, tars and dirt from oil and oil products.

Specifications

Stress analysis code	ASME Section VIII Division 1.
Connection Flange	JIS B 2210, ANSI B 16.5, DIN, etc.
Materials	
Body	Carbon Steel, Stainless Steel, Bronze, etc.
Filter	Carbon Steel, Stainless Steel, Monel, Titanium, etc.
Packing	N.B.R, E.P.D.M, P.T.F.E, Viton, Non-Asbestos, etc.
Filter	ø2 - ø12
Mesh	N/A
Lifting	Lug, Eye bolt, etc.
Cover bolting	Stud
Vent / Drain type	Screw, Flange, Valve, etc.
Coating	Tar Free Epoxy, N.B.R, P.E, Hot Dipped Galv, etc.
Liquid name	Water, etc.

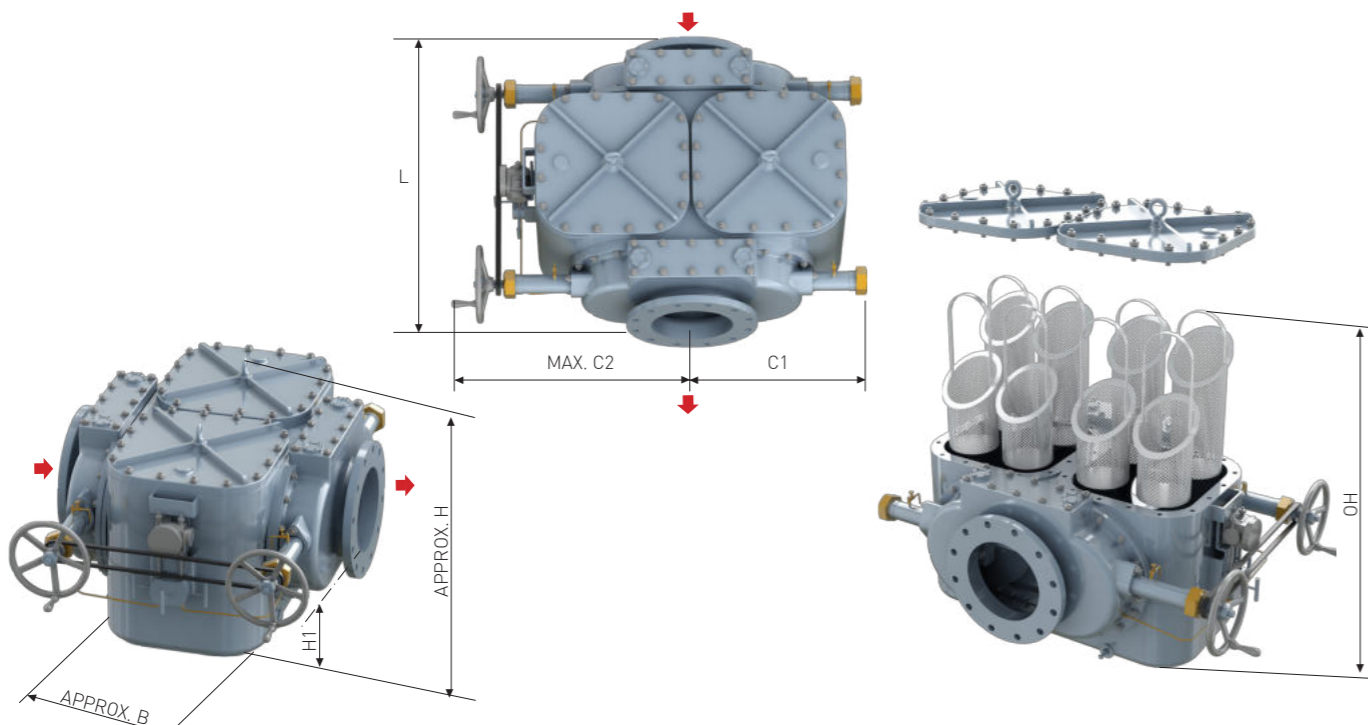

DIMENSION TABLE

Nominal dia	L	C1	C2	B	H1	H	OH	DRAIN/VENT PLUG.	Net Weight(kg)
200A	978	458	724	465	210	521	966	3/4"	910
250A	1029	516	775	521	264	604	1118	3/4"	1555
300A	1105	595	826	585	343	743	1321	3/4"	1986
350A	1176	651	889	633	401	803	1524	3/4"	2397
400A	1260	707	953	714	453	889	1677	3/4"	2985
500A	1626	864	1113	859	677	1163	2236	3/4"	5045
600A	1773	1027	1258	930	750	1347	2490	3/4"	5772
750A	2515	1677	1829	1169	991	1702	3150	3/4"	9600
900A	3023	1677	1829	1194	991	1702	3150	3/4"	9980

* We can provide bigger size strainers.

B
PRODUCT

DUPLEX STRAINERS
BUTTERFLY VALVE H TYPE (M/N:DS1)



General

Butterfly Valve H Type is a simple, economical, and trouble free design... time tested in applications around the world over many years. This type of strainer is actually a high quality, pressure rated butterfly valve with integral straining filters. Switching the flow from one filter to the other is accomplished by moving the operating handle through a 90 degree arc. The design is such that is impossible for this operation to stop the flow because of the unique port design in the diverter plug. The plug is automatically positioned each time in exactly the right spot by integral stops.

Specifications

Stress analysis code	ASME Section VIII Division 1.
Connection Flange	JIS B 2210, ANSI B 16.5, DIN, etc.
Materials	
Body	Carbon Steel, Stainless Steel, etc.
Filter	Carbon Steel, Stainless Steel, Monel, Titanium, etc.
Packing	N.B.R, E.P.D.M, P.T.F.E, Viton, Non-Asbestos, S.W.C, etc.
Butterfly valve type	Metal seat, Teflon, E.P.D.M, etc.
Filter	ø2 - ø12
Mesh	#2 - #400 / 11100 - 35 micron
Lifting	Handle, Davit, Lug, etc.
Cover bolting	Stud, Hexagon, etc.
Vent / Drain type	Screw, Flange, Valve, etc.
Coating	Tar Free Epoxy, N.B.R, P.E, Hot Dipped Galv, etc.
Liquid name	Oil, Water, etc.

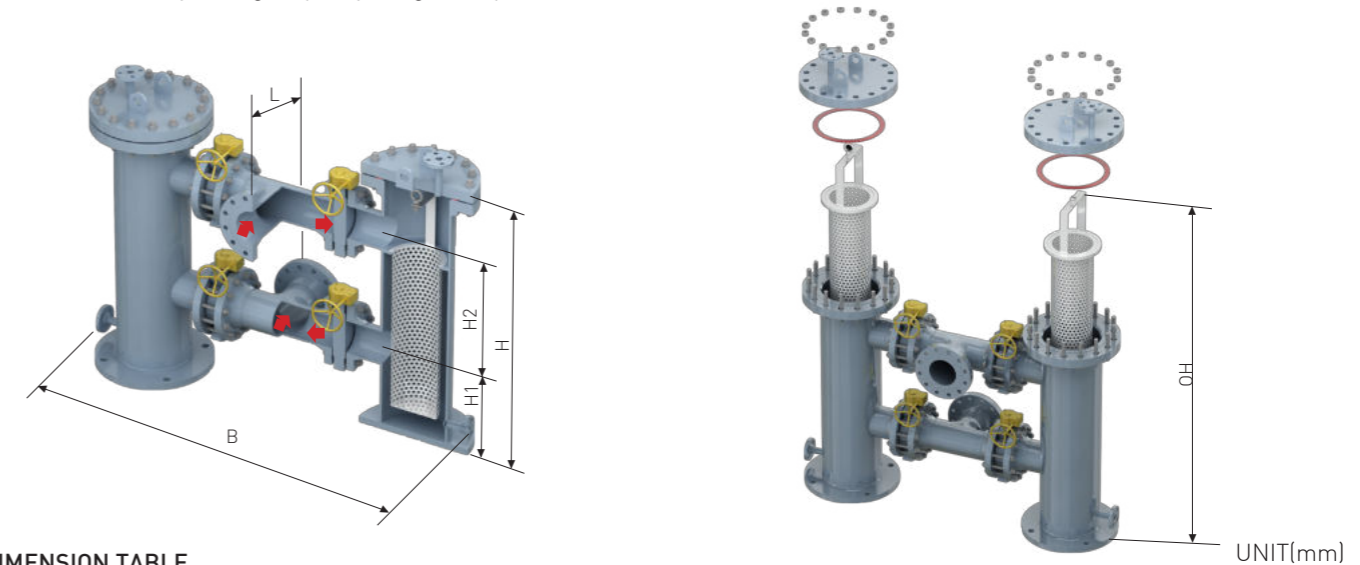

DIMENSION TABLE

Nominal dia		L		B		H1	H2	H		OH		Net Weight(kg)	
JIS	ANSI	5K 150LB	10K 300LB	5K 150LB	10K 300LB			5K 150LB	10K 300LB	5K 150LB	10K 300LB	5K 150LB	10K 300LB
50A	2"	254	266.5	724	749	110	300	530	550	1030	1065	194	228
65A	2 1/2"	292	305	762	789	130	320	580	600	1120	1160	232	278
80A	3"	311.5	330.5	825	865	150	350	640	665	1240	1290	268	341
100A	4"	361.5	380.5	972	1010	200	400	760	796	1465	1535	373	489
125A	5"	426	445	1116	1154	220	430	830	880	1595	1695	492	604
150A	6"	463	482	1155	1198	250	450	890	940	1730	1830	525	836
200A	8"	559	579	1365	1402	300	500	1030	1090	2005	2125	898	1223
250A	10"	635	667	1475	1571	330	600	1200	1250	2325	2425	1182	1832
300A	12"	736.5	768.5	1677	1780	360	700	1380	1440	2680	2800	1678	2476
350A	14"	813	844.5	1855	1977	400	800	1550	1620	2995	3130	2217	3302
400A	16"	864	902	1976	2126	450	900	1730	1780	3380	3480	2945	4164
450A	18"	965	1003.5	2181	2320	550	1000	1970	2030	3835	3955	3532	5434
500A	20"	1051	1086	2373	2572	600	1200	2165	2215	4235	4335	4592	7324
600A	24"	1169	1200.5	2665	2831	700	1450	2670	2780	5220	5435	6750	11043

* We can provide bigger size strainers.

DUPLEX STRAINERS
3-WAY BALL VALVE TYPE (M/N:DS2)

B
PRODUCT

General

3-Way Ball Valve Type is a simple, economical, and trouble free design... time tested in applications around the world over many years. This type of strainer is actually a high quality, pressure rated 3-way ball valve with integral straining filters. Switching the flow from one filter to the other is accomplished by moving the operating handle through a 90 degree arc. The design is such that it is impossible for this operation to stop the flow because of the unique port design in the diverter plug. The plug is automatically positioned each time in exactly the right spot by integral stops.



Specifications

Stress analysis code	ASME Section VIII Division 1.
Connection Flange	JIS B 2210, ANSI B 16.5, DIN, etc.
Materials	
Body	Carbon Steel, Stainless Steel, etc.
Filter	Carbon Steel, Stainless Steel, Monel, Titanium, etc.
Packing	N.B.R, E.P.D.M, P.T.F.E, Viton, Non-Asbestos, S.W.C, etc.
Butterfly valve type	Metal seat, Teflon, E.P.D.M, etc.
Filter	ø2 ~ ø12
Mesh	#2 ~ #400 / 11100 ~ 35 micron
Lifting	Handle, Davit, Lug, etc.
Cover bolting	Stud, Hexagon, etc.
Vent / Drain type	Screw, Flange, Valve, etc.
Coating	Tar Free Epoxy, N.B.R, P.E, Hot Dipped Galv, etc.
Liquid name	Oil, Water, etc.

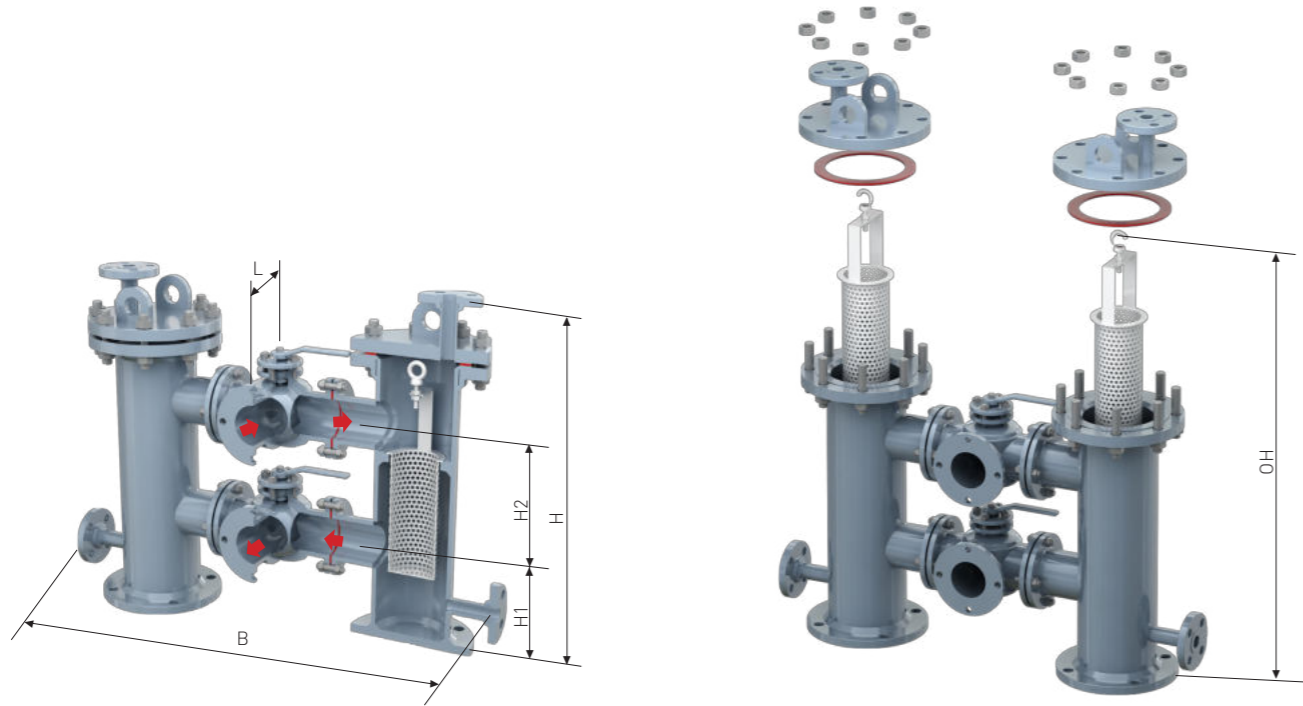

DIMENSION TABLE

Nominal dia	L	B	H2	H1	H	OH	Net Weight(kg)
							5K-150LB
40A	140	915	400	280	966	1524	156
50A	140	925	450	280	991	1550	228
80A	140	966	500	280	1105	1702	278
100A	172	1232	550	305	1197	1905	341
150A	204	1524	650	331	1456	2337	489
200A	267	1837	800	381	1867	3252	836

* We can provide bigger size strainers.

www.woosungflowtec.com

Y STRAINERS
CASTING (M/N:YC)

B
PRODUCT

General

Y Strainers for casting take their name from their configuration. They are most commonly used in pressurized lines, gas or liquid, but can also be used in suction or vacuum conditions. They are intended for applications where small amounts of solid particulate are expected, and where clean-out will be infrequent. If solids will flush easily from the screen, and fluid can be exhausted to atmosphere, a blow-down valve on the drain port will allow clean-out without removal of the screen, and without interrupting the process flow.

Specifications

Stress analysis code	ASME Section VIII Division 1.
Connection Flange	JIS B 2210, ANSI B 16.5, DIN, etc.
Materials	
Body	Carbon Steel, Stainless Steel, Bronze, etc.
Filter	Carbon Steel, Stainless Steel, Monel, Titanium, etc.
Packing	N.B.R, E.P.D.M, P.T.F.E, Viton, Non-Asbestos, S.W.G, etc.
Filter	ø2 ~ ø12
Mesh	#2 ~ #400 / 11100 ~ 35 micron
Lifting	Lug
Cover bolting	Stud, Hexagon
Vent / Drain type	Screw, Flange, Valve, etc.
Coating	Tar Free Epoxy, N.B.R, P.E, Hot Dipped Galv, etc.
Liquid name	Oil, Water, Steam, Gas, etc.

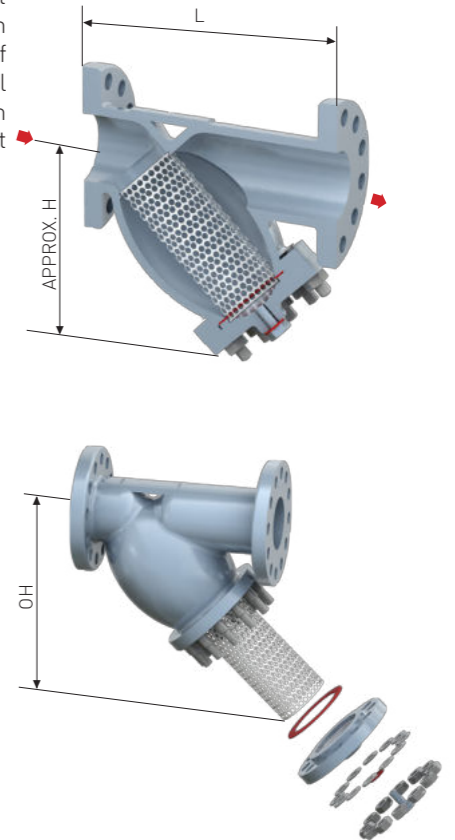

DIMENSION TABLE

Nominal dia	JIS-5K				JIS-10K				150LB				300LB			
	L	H	OH	Net Weight(kg)	L	H	OH	Net Weight(kg)	L	H	OH	Net Weight(kg)	L	H	OH	Net Weight(kg)
15A	180	111	122	7.5	180	111	122	9	180	111	122	9	180	111	122	9
20A	190	111	122	8	190	111	122	10	190	111	122	10	190	111	122	10
25A	190	122	145	9	190	122	145	12	190	122	145	12	190	122	145	12
32A	218	143	163	12	218	143	215	15	218	143	215	15	248	143	163	17
40A	218	143	163	13	218	143	215	16	218	143	215	16	248	143	163	18
50A	255	156	181	14	255	156	244	18	255	156	244	18	260	156	181	19
65A	280	219	272	23	280	219	337	28	280	219	337	28	320	219	224	28
80A	322	240	309	30	322	240	393	33	322	240	393	33	360	240	309	38
100A	348	265	336	37	348	265	439	40	348	265	439	40	410	265	336	46
125A	394	317	415	55	394	317	523	62	394	317	523	62	434	317	415	65
150A	442	355	474	70	442	355	586	78	442	355	586	78	515	355	494	85
200A	590	484	720	143	590	484	913	149	590	484	913	149	620	484	670	193
250A	680	583	840	205	680	583	976	210	680	583	976	210	715	583	976	245
300A	775	660	1175	368	775	660	1175	378	775	660	1175	378	775	660	1175	430

Nominal dia	600LB				900LB				1500LB				2500LB			
	L	H	OH	Net Weight(kg)	L	H	OH	Net Weight(kg)	L	H	OH	Net Weight(kg)	L	H	OH	Net Weight(kg)
15A	225	119	135	9	206	108	195	11	350	215	230	25	350	215	230	28
20A	225	119	135	10	230	121	218	15	350	215	230	26	350	215	230	29
25A	225	119	135	12	271	146	263	22	350	215	230	38	350	215	230	42
32A	295	155	170	19	280	155	279	48	450	261	270	76	450	261	270	84
40A	295	155	170	20	280	155	279	50	450	261	270	80	450	261	270	88
50A	340	195	230	22	315	170	306	57	460	292	350	97	460	292	350	107
65A	385	207	250	30	470	282	350	66	520	328	414	106	660	400	492	117
80A	480	320	390	40	530	382	430	74	680	380	492	148	680	417	720	170
100A	520	328	576	50	590	360	450	115	590	417	684	220	860	515	927	253
125A	574	400	720	72	630	430	774	160	700	450	810	311	950	550	990	358
150A	628	460	820	95	720	515	927	250	790	520	936	425	1000	585	1053	488
200A	840	550	990	220	890	645	1161	488	990	685	1233	724	-	-	-	-
250A	980	710	1278	270	-	-	-	-	-	-	-	-	-	-	-	-
300A	1110	810	1458	475	-	-	-	-	-	-	-	-	-	-	-	-

* We can provide bigger size strainers.

www.woosungflowtec.com

Y STRAINERS
FORGED 150LB ~ 600LB (M/N:YF)

B
PRODUCT



General

Y Strainers for forged take their name from their configuration. They are most commonly used in pressurized lines, gas or liquid, but can also be used in suction or vacuum conditions. They are intended for applications where small amounts of solid particulate are expected, and where clean-out will be infrequent. If solids will flush easily from the screen, and fluid can be exhausted to atmosphere, a blow-down valve on the drain port will allow clean-out without removal of the screen, and without interrupting the process flow.

Specifications

Stress analysis code	ASME Section VIII Division 1.
Connection Flange	JIS B 2210, ANSI B 16.5, DIN, etc.
Materials	
Body	Carbon Steel, Stainless Steel, etc.
Filter	Carbon Steel, Stainless Steel, Monel, Titanium, etc.
Packing	N.B.R, E.P.D.M, P.T.F.E, Viton, Non-Asbestos, S.W.G, etc.
Filter	ø2 ~ ø12
Mesh	#2 ~ #400 / 11100 ~ 35 micron
Lifting	N/A
Cover bolting	Hexagon
Vent / Drain type	Screw, Flange, Valve, etc.
Coating	Tar Free Epoxy, N.B.R, P.E, Hot Dipped Galv, etc.
Liquid name	Oil, Water, Steam, Gas, etc.

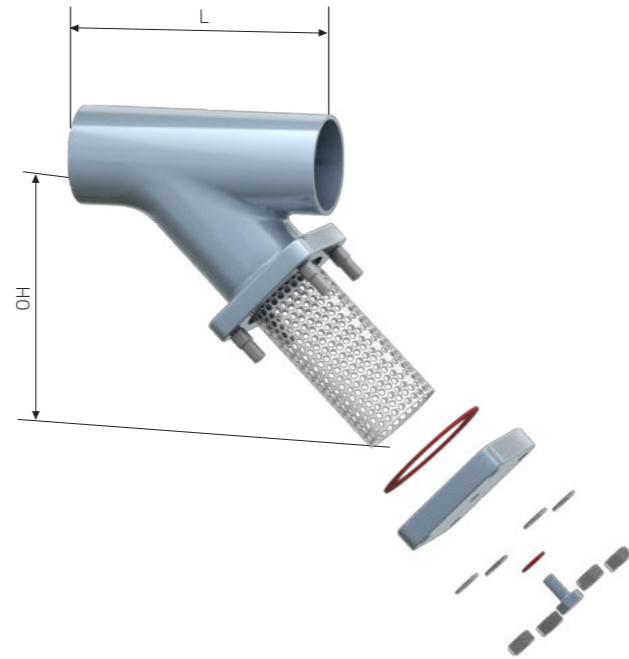
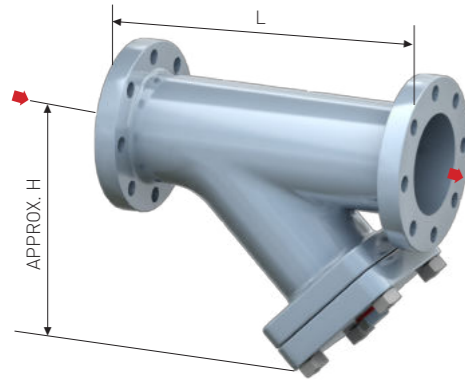

DIMENSION TABLE

Nominal dia.		150LB				300LB				600LB			
		L		H	OH	Net Weight(kg)		L		H	OH	Net Weight(kg)	
mm	(")	SW	BW			SW	BW	SW	BW			SW	BW
15A	1/2"	180	120	195	8.5	180	120	195	7.5	180	120	195	8.5
20A	3/4"	180	120	195	10	180	120	195	8	180	120	195	10
25A	1"	180	120	195	12	180	120	195	9	180	120	195	12
32A	1 1/4"	248	130	215	15	218	130	215	12	248	130	215	15
40A	1 1/2"	248	130	215	18	218	130	215	13	248	130	215	18
50A	2"	260	150	244	19	255	150	244	14	260	150	244	19

Y STRAINERS
STEEL PLATE (M/N:YS)

B
PRODUCT



General

Y Strainers for steel plate take their name from their configuration. They are most commonly used in pressurized lines, gas or liquid, but can also be used in suction or vacuum conditions. They are intended for applications where small amounts of solid particulate are expected, and where clean-out will be infrequent. If solids will flush easily from the screen, and fluid can be exhausted to atmosphere, a blow-down valve on the drain port will allow clean-out without removal of the screen, and without interrupting the process flow.

Specifications

Stress analysis code	ASME Section VIII Division 1.
Connection Flange	JIS B 2210, ANSI B 16.5, DIN, etc.
Flange Rating	150LB, 300LB, 400LB, 600LB, 900LB, 1500LB, 2500LB
Materials	
Body	Carbon Steel, Stainless Steel, Bronze, etc.
Filter	Carbon Steel, Stainless Steel, Monel, Titanium, etc.
Packing	N.B.R, E.P.D.M, P.T.F.E, Viton, Non-Asbestos, S.W.G, etc.
Filter	ø2 ~ ø12
Mesh	#2 ~ #400 / 11100 ~ 35 micron
Lifting	Lug
Cover bolting	Stud, Hexagon
Vent / Drain type	Screw, Flange, Valve, etc.
Coating	Tar Free Epoxy, N.B.R, P.E, Hot Dipped Galv, etc.
Liquid name	Oil, Water, Steam, Gas, etc.

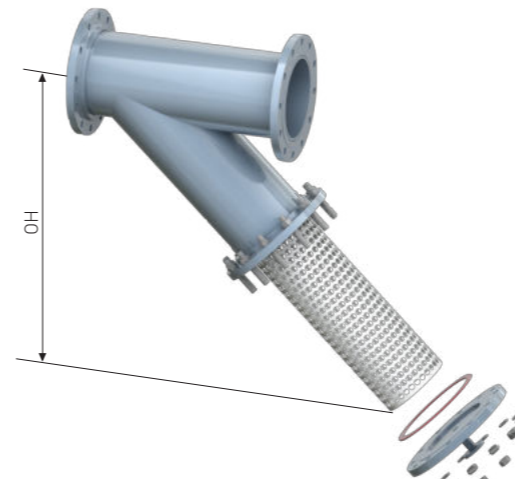
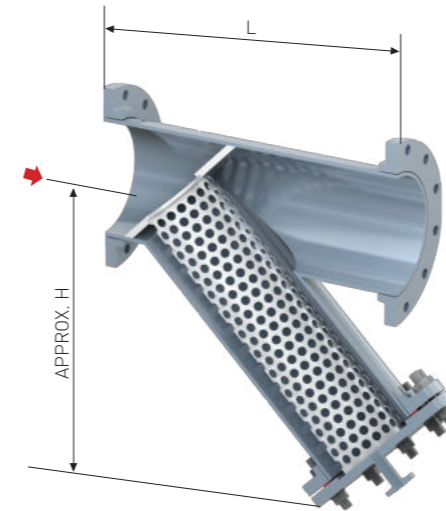

DIMENSION TABLE

Nominal dia	L		H		OH		Net Weight(kg)			
	150LB	300LB	150LB	300LB	150LB	300LB	B/W		FLANGE	
							150LB	300LB	150LB	300LB
50A	290	370	241	247	390	390	10	13	15	20
65A	320	440	272	284	440	440	15	21	24	32
80A	350	490	298	312	490	490	20	28	30	44
100A	410	580	340	355	550	550	30	45	44	68
125A	490	670	382	395	620	620	43	61	60	91
150A	540	700	415	432	670	670	57	82	77	122
200A	660	840	507	526	790	950	97	138	130	199
250A	770	940	593	612	1050	1100	152	220	198	306
300A	880	1080	704	729	1240	1300	228	315	301	446
350A	970	1170	771	795	1350	1430	275	401	375	585
400A	1030	1290	874	906	1520	1600	356	591	485	816
450A	1160	1300	969	1000	1640	1750	442	707	594	995
500A	1270	1330	1060	1095	1800	1910	655	871	832	1206
550A	1370	1440	1167	1211	1980	2090	805	968	999	1543
600A	1460	1550	1268	1316	2130	2187	947	1296	1212	1767
650A	1600	1800	1409	1452	2187	2270	1287	1706	1554	2275
700A	1750	1950	1519	1568	2380	2380	1448	2046	1889	2754
750A	1850	2000	1618	1680	2545	2545	1749	2353	2107	3203
800A	2000	2200	1733	1789	2714	2714	2039	2728	2502	3689
850A	2100	2300	1852	1908	2910	2910	2340	3105	2833	4204
900A	2250	2450	1960	2016	3085	3085	2718	3545	3309	4770
950A	2350	2550	2077	2067	3275	3275	3006	4082	3678	5797
1000A	2500	2700	2171	2174	3435	3435	3340	4561	4061	6418

TEE STRAINERS
ANGLE FLOW TYPE (M/N:T1/T2)



Specifications

Stress analysis code	ASME Section VIII Division 1.
Connection Flange	JIS B 2210, ANSI B 16.5, DIN, etc.
Flange Rating	150LB, 300LB, 400LB, 600LB, 900LB, 1500LB, 2500LB
Materials	
Body	Carbon Steel, Stainless Steel, etc.
Filter	Carbon Steel, Stainless Steel, Monel, Titanium, etc.
Packing	N.B.R, E.P.D.M, P.T.F.E, Viton, Non-Asbestos, S.W.G, etc.
Filter	ø2 ~ ø12
Mesh	#2 ~ #400 / 11100 ~ 35 micron
Lifting	Handle, Davit, Lug, etc.
Cover bolting	Stud, Hexagon, etc.
Vent / Drain type	Screw, Flange, Valve, etc.
Coating	Tar Free Epoxy, N.B.R, P.E, Hot Dipped Galv, etc.
Liquid name	Oil, Water, Steam, Gas, etc.

General

Tee angle strainer is similar to the standard tee strainer except that it is designed for angled flow. The strainer can be fabricated with a standard bolted cover or a quick opening hinged cover. The strainer can be fabricated to meet your specifications. The standard strainer is constructed of carbon or stainless steel material. Other materials, end connections and accessories are available

* Option : Flange END, PWHT, Internal Paint, Bolt/Nut Coating, Davit or Hinge, Nace

FLOW DIRECTION

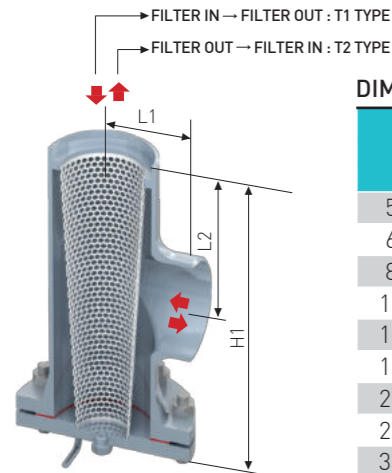

DIMENSION TABLE

UNIT(mm)

Nominal dia.	L1		L2		H1		OH	Net Weight(kg)				Applicable filter types	
	B/W	FLANGE	B/W	FLANGE	150LB	300LB		B/W		FLANGE			
								150LB	300LB	150LB	300LB		
50A	2"	64	128	128	128	279	295	500	9	12	14	19	
65A	2.5"	76	146	146	146	318	334	623	14	18	22	29	
80A	3"	86	156	156	156	340	364	671	17	24	27	40	
100A	4"	105	181	181	181	391	418	783	25	37	39	61	
125A	5"	124	213	213	213	454	484	924	36	50	53	81	
150A	6"	143	232	232	232	494	524	1013	46	67	67	108	
200A	8"	178	280	280	280	592	624	1227	75	110	110	172	
250A	10"	216	318	318	318	670	719	1405	115	174	163	263	
300A	12"	254	368	368	368	773	824	1634	173	250	249	381	
350A	14"	279	406	406	406	852	902	1801	212	326	312	508	
400A	16"	305	432	432	432	905	964	1927	272	450	400	679	
450A	18"	343	483	483	483	1010	1090	2156	342	566	491	846	
500A	20"	381	526	526	526	1100	1154	2351	472	684	653	1026	
550A	22"	419	569	569	569	1188	1240	2549	575	881	777	1315	
600A	24"	432	584	584	584	1221	1275	2638	664	989	928	1474	
650A	26"	495	618	618	618	1308	1384	2792	830	1139	1107	1554	
700A	28"	521	648	648	648	1335	1425	2935	956	1358	1272	1856	
750A	30"	559	698	698	698	1370	1458	3160	1106	1572	1478	2156	
800A	32"	597	743	743	743	1571	1665	3368	1357	1837	1823	2530	
850A	34"	635	786	786	786	1658	1759	3563	1519	2010	2017	2882	
900A	36"	673	832	832	832	1758	1860	3775	1761	2109	2348	3064	
950A	38"	711	870	870	870	1831	1872	3952	1938	2318	2620	3267	
1000A	40"	725	885	915	915	1924	1974	4157	2138	2392	2854	3355	
1050A	42"	749	915	936	936	1971	2019	4263	2404	2568	3223	3415	
1100A	44"	762	942	993	993	2091	2138	4518	2704	2896	3615	3837	
1150A	46"	800	988	1039	1039	2184	2236	4728	2933	3265	3914	4326	
1200A	48"	838	1032	1083	1083	2277	2331	4929	3266	3600	4350	4773	

* We can provide bigger size strainers.

www.woosungflowtec.com

TEE STRAINERS
STRAIGHT FLOW TYPE (M/N:T3R)



General

Tee strainers for straight flow type are installed at 90° bend piping. The cylindrical element housed in the body can be taken out to horizontal center line by removing the cover.

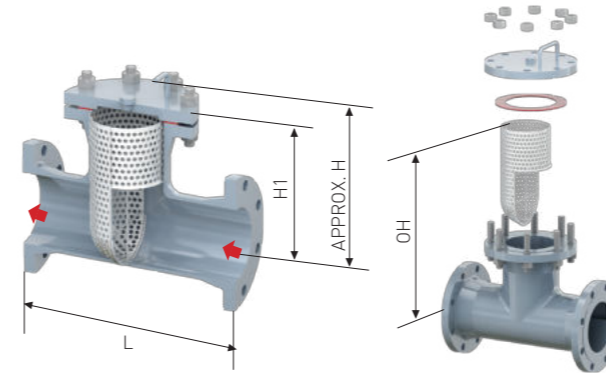

Specifications

Stress analysis code	ASME Section VIII Division 1.
Connection Flange	JIS B 2210, ANSI B 16.5, DIN, etc.
Flange Rating	150LB, 300LB, 400LB, 600LB, 900LB, 1500LB, 2500LB
Materials	
Body	Carbon Steel, Stainless Steel, etc.
Filter	Carbon Steel, Stainless Steel, Monel, Titanium, etc.
Packing	N.B.R, E.P.D.M, P.T.F.E, Viton, Non-Asbestos, S.W.G, etc.
Filter	ø2 ~ ø12
Mesh	#2 ~ #400 / 11100 ~ 35 micron
Lifting	Handle, Davit, Lug, etc.
Cover bolting	Stud, Hexagon, etc.
Vent / Drain type	Screw, Flange, Valve, etc.
Coating	Tar Free Epoxy, N.B.R, P.E, Hot Dipped Galv, etc.
Liquid name	Oil, Water, Steam, Gas, etc.

DIMENSION TABLE

UNIT(mm)

Nominal dia.	L		H1		APPROX. H		APPROX. OH		Net Weight(kg)				Applicable filter types		
	BW	FLANGE	150LB	300LB	150LB	300LB	150LB	300LB	BW		FLANGE				
									150LB	300LB	150LB	300LB			
80A	171.5	171.5	311.1	330.3	155.5	165.1	250	270	360	380	20	23	34	39	R
100A	209.6	209.6	362	381	181	190.5	280	300	420	440	24	36	40	61	R
125A	247.7	247.7	425.5	444.5	212.7	222.2	310	330	500	520	32	47	52	81	R
150A	285.8	285.8	463.6	482.6	231.8	241.3	330	350	550	570	42	64	66	108	R
200A	355.6	355.6	558.8	577.8	279.4	288.9	380	410	670	690	69	102	109	169	R
250A	431.8	431.8	635	666.8	317.5	333.4	420	460	780	810	106	162	159	258	R
300A	508	508	736.6	768.4	368.3	384.2	480	510	900	940	159	222	244	332	R
350A	558.8	558.8	812.8	844.6	406.4	422.3	520	550	1000	1030	211	319	325	515	R
400A	609.6	609.6	863.6	901.6	431.8	450.8	540	580	1070	1110	279	421	421	670	R
450A	685.8	685.8	963.8	1003.4	481.9	501.7	600	640	1200	1240	344	523	506	825	R
500A	762	762	1051	1085.8	525.5	542.9	640	680	1310	1340	434	638	635	1004	R
550A	838.2	838.2	1137	1168.4	568.5	584.2	690	730	1420	1450	524	789	751	1211	R
600A	863.6	863.6	1168.4	1200.2	584.2	600.1	710	740	1480	1510	605	933	878	1462	R
650A	990.6	990.6	1232.6	1358.6	616.3	679.3	760	830	1570	1690	827	1175	1143	1775	R
700A	1041.4	1041.4	1291.4	1435.4	645.7	717.7	790	880	1650	1800	954	1395	1314	2117	R
750A	1117.6	1117.6	1391.6	1537.6	695.8	768.8	850	940	1780	1920	1103	1626	1524	2460	R
800A	1193.8	1193.8	1482.8	1637.8	741.4	818.9	900	990	1890	2050	1359	1897	1884	2854	R
850A	1270	1270	1568	1734	784	867	940	1040	2000	2170	1518	1992	2080	3220	R
900A	1346.2	1346.2	1660.2	1784	830.1	892.2	1000	1080	2120	2270	1768	2137	2431	3644	R
950A	1422.4	1422.4	1736.4	1828	868.2	911.2	1030	1090	2220	2290	1940	2324	2680	3863	R
1000A	1498.6	1498.6	1826.6	1886.6	882.7	914.1	1050	1110	2300	2360	2152	2445	2950	4031	R
1050A	1524	1524	1867	1924	913.3	943.3	1080	1130	2340	2400	2388	2527	3302	4111	R
1100A	1625.6	1625.6	1981.6	2037.6	940	968	1120	1170	2440	2500	2701	2892	3718	4297	R
1150A	1701.8	1701.8	2073.8	2133.8	986.1	1016.1	1160	1220	2560	2620	2918	3254	4004	4414	R
1200A	1778	1778	2162	2226	1030.2	1062.2	1210	1270	2670	2740	3252	3571	4452	4804	R

* We can provide bigger size strainers.

www.woosungflowtec.com

TEE STRAINERS
STRAIGHT FLOW TYPE (M/N:T3W(WV&WW))

B
PRODUCT

General

Tee strainers for straight flow type are installed at 90° bend piping. The cylindrical element housed in the body can be taken out to horizontal center line by removing the cover.

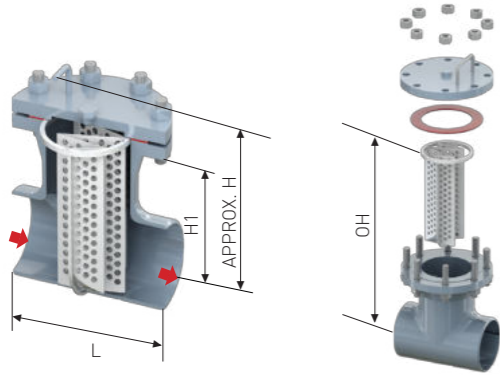

Specifications

Stress analysis code	ASME Section VIII Division 1.
Connection Flange	JIS B 2210, ANSI B 16.5, DIN, etc.
Flange Rating	150LB, 300LB, 400LB, 600LB, 900LB, 1500LB, 2500LB
Materials	
Body	Carbon Steel, Stainless Steel, etc.
Filter	Carbon Steel, Stainless Steel, Monel, Titanium, etc.
Packing	N.B.R, E.P.D.M, P.T.F.E, Viton, Non-Asbestos, S.W.G, etc.
Filter	ø2 ~ ø12
Mesh	#2 ~ #400 / 11100 ~ 35 micron
Lifting	Handle, Davit, Lug, etc.
Cover bolting	Stud, Hexagon, etc.
Vent / Drain type	Screw, Flange, Valve, etc.
Coating	Tar Free Epoxy, N.B.R, P.E, Hot Dipped Galv, etc.
Liquid name	Oil, Water, Steam, Gas, etc.

DIMENSION TABLE

Nominal dia.	L														Applicable filter types
	BW		FLANGE		H1		APPROX. H		APPROX. OH		Net Weight(kg)				
	150LB	300LB	150LB	300LB	150LB	300LB	150LB	300LB	150LB	300LB	BW	FLANGE	150LB	300LB	
150A	285.8	285.8	463.6	482.6	231.8	241.3	330	350	550	570	42	64	66	108	WV,WW
200A	355.6	355.6	558.8	577.8	279.4	288.9	380	410	670	690	69	102	109	169	WV,WW
250A	431.8	431.8	635	666.8	317.5	333.4	420	460	780	810	106	162	159	258	WV,WW
300A	508	508	736.6	768.4	368.3	384.2	480	510	900	940	159	222	244	332	WV,WW
350A	558.8	558.8	812.8	844.6	406.4	422.3	520	550	1000	1030	211	319	325	515	WV,WW
400A	609.6	609.6	863.6	901.6	431.8	450.8	540	580	1070	1110	279	421	421	670	WV,WW
450A	685.8	685.8	963.8	1003.4	481.9	501.7	600	640	1200	1240	344	523	506	825	WV,WW
500A	762	762	1051	1085.8	525.5	542.9	640	680	1310	1340	434	638	635	1004	WV,WW
550A	838.2	838.2	1137	1168.4	568.5	584.2	690	730	1420	1450	524	789	751	1211	WV,WW
600A	863.6	863.6	1168.4	1200.2	584.2	600.1	710	740	1480	1510	605	933	878	1462	WV,WW
650A	990.6	990.6	1232.6	1358.6	616.3	679.3	760	830	1570	1690	827	1175	1143	1775	WV,WW
700A	1041.4	1041.4	1291.4	1435.4	645.7	717.7	790	880	1650	1800	954	1395	1314	2117	WV,WW
750A	1117.6	1117.6	1391.6	1537.6	695.8	768.8	850	940	1780	1920	1103	1626	1524	2460	WV,WW
800A	1193.8	1193.8	1482.8	1637.8	741.4	818.9	900	990	1890	2050	1359	1897	1884	2854	WV,WW
850A	1270	1270	1568	1734	784	867	940	1040	2000	2170	1518	1992	2080	3220	WV,WW
900A	1346.2	1346.2	1660.2	1784	830.1	892.2	1000	1080	2120	2270	1768	2137	2431	3644	WV,WW
950A	1422.4	1422.4	1736.4	1828	868.2	911.2	1030	1090	2220	2290	1940	2324	2680	3863	WV,WW
1000A	1498.6	1498.6	1826.6	1886.6	882.7	914.1	1050	1110	2300	2360	2152	2445	2950	4031	WV,WW
1050A	1524	1524	1867	1924	913.3	943.3	1080	1130	2340	2400	2388	2527	3302	4111	WV,WW
1100A	1625.6	1625.6	1981.6	2037.6	940	968	1120	1170	2440	2500	2701	2892	3718	4297	WV,WW
1150A	1701.8	1701.8	2073.8	2133.8	986.1	1016.1	1160	1220	2560	2620	2918	3254	4004	4414	WV,WW
1200A	1778	1778	2162	2226	1030.2	1062.2	1210	1270	2670	2740	3252	3571	4452	4804	WV,WW

* We can provide bigger size strainers.

www.woosungflowtec.com

TEMPORARY STRAINERS
FLAT TYPE (M/N:CF) / CONICAL TYPE (M/N:CC)
BASKET TYPE (M/N:CB) / W TYPE (M/N:CW)

B
PRODUCT

Specifications

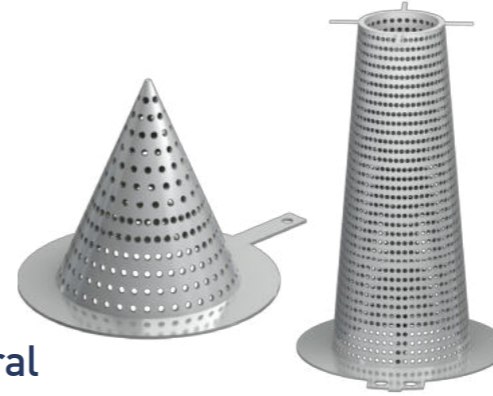

General

They shall be used for flushing before starting regular operation of the piping. These type are temporary strainers, which are installed between flanges of piping line.

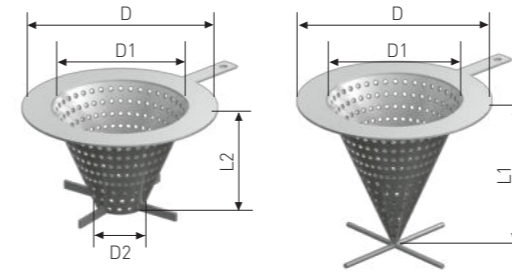

BASKET Type (65A~2100A)

CONICAL Type (25A~2100A)

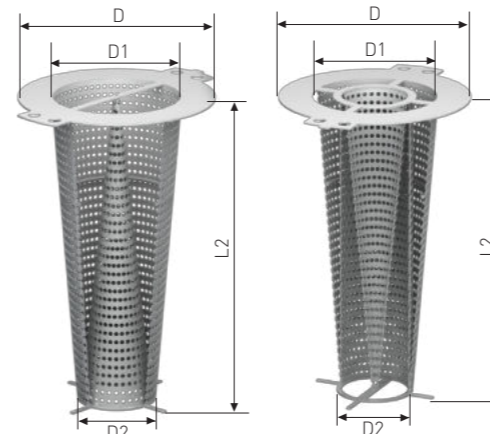

W Type (65A~2100A)

VW Type (65A~2100A)

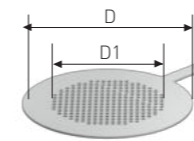

FLAT Type (65A~2100A)

Stress analysis code	ASME Section VIII Division 1.
Connection Flange	JIS B 2210, ANSI B 16.5, DIN, etc.
Flange Rating	150LB, 300LB, 400LB, 600LB, 900LB, 1500LB, 2500LB
Materials	
Filter	Stainless Steel, Monel, Titanium, etc.
Filter	ø2 ~ ø12
Mesh	#2 ~ #400 / 11100 ~ 35 micron
Lifting	Handle
Cover bolting	N/A
Liquid name	Oil, Water, Steam, Gas, etc.

DIMENSION TABLE

UNIT(mm)

Nominal dia.	D		D1	D2	L1	L2	Net Weight(kg)		
	150LB	300LB					CONICAL (FLAT)	BASKET	W(VW)
25A	64	70	23	-	40	-	0.2(0.1)	-	-
32A	73	80	30	-	45	-	0.3(0.2)	-	-
40A	83	92	36	-	50	-	0.4(0.3)	-	-
50A	102	108	46	-	60	-	0.5(0.4)	-	-
65A	121	127	58	35	70	80	0.6(0.5)	0.6	0.7(0.9)
80A	134	149	70	45	85	100	0.7(0.6)	0.8	0.9(1.1)
100A	172	181	93	60	115	110	1.1(0.7)	1.2	1.4(1.7)
125A	194	213	115	75	145	140	1.4(0.8)	1.6	1.9(2.3)
150A	220	248	135	90	180	170	1.8(0.9)	2.1	2.6(3.2)
200A	277	308	185	125	230	210	3.8(2)	3.3	4.1(5.2)
250A	337	362	235	150	295	270	5.5(3)	4.9	6.2(7.8)
300A	407	426	275	180	365	325	8.2(4)	7.2	9.0(11)
350A	447	485	305	205	390	350	8.8(5)	7.8	9.8(12)
400A	511	543	350	245	455	400	9.5(6)	11	13(16)
450A	546	597	400	270	510	450	11(7)	12	14(18)
500A	603	651	450	305	570	500	18(12)	14	17(21)
550A	657	657	500	335	625	550	21(13)	16	20(25)
600A	715	715	550	360	675	600	24(16)	19	24(30)
650A	772	772	595	385	730	650	28(17)	28	35(46)
700A	829	829	645	415	780	700	32(19)	39	48(60)
750A	880	880	695	450	835	750	35(20)	43	54(67)
800A	937	937	740	470	885	800	40(23)	49	60(76)
850A	987	987	790	500	945	850	44(25)	54	67(84)
900A	1045	1045	840	530	995	900	45(28)	55	69(87)
950A	1108	1108	890	560	1060	950	51(31)	62	77(97)
1000A	1159	1159	930	600	1130	1000	56(34)	69	86(108)
1050A	1216	1216	975	630	1180	1050	62(38)	76	95(119)
1100A	1273	1273	1020	650	1240	1100	68(41)	83	103(129)
1150A	1324	1324	1070	680	1285	1150	70(44)	86	107(134)
1200A	1381	1381	1120	710	1350	1200	76(47)	93	116(146)
1250A	1432	1432	1160	740	1410	1250	82(51)	100	126(158)
1300A	1489	1489	1210	770	1460	1300	88(55)	108	136(170)
1350A	1546	1546	1260	800	1520	1350	90(59)	111	140(175)
1500A	1711	1711	1400	890	1700	1500	110(71)	136	172(215)
1650A	1883	1883	1540	980	1850	1650	122(86)	151	190(238)
1800A	2048	2048	1680	1060	2030	1800	144(101)	178	224(280)
1950A	2207	2207	1830	1150	2200	1950	165(114)	205	259(324)
2100A	2372	2372	1970	1250	2360	2100	189(132)	237	300(376)

* We can provide bigger size strainers.

www.woosungflowtec.com

MUD / ROSE BOXES
MUD BOXES FOR CASTING (M/N:MC1)

Specifications

Stress analysis code	ASME Section VIII Division 1.
Connection Flange	JIS B 2210, ANSI B 16.5, DIN, etc.
Materials	
Body	Carbon Steel, Stainless Steel, Bronze, etc.
Filter	Carbon Steel, Stainless Steel, Monel, Titanium, etc.
Packing	N.B.R, E.P.D.M, P.T.F.E, Viton, etc.
Filter	ø2 - ø19
Mesh	N/A
Lifting	Ring, Yoke
Cover bolting	Yoke, Stud bolt, Eye bolt
Drain type	Screw, Flange, Valve, etc.
Coating	Tar Free Epoxy, N.B.R, P.E, Hot Dipped Galv, etc.
Liquid name	Water, Oily Water, Gas, etc.



General

Mud Boxes for casting are available with bolted or quick release yoked cover. Yoke cover units are ideally suited for applications where frequent clean-out of the filter is expected. Having a spare, clean filter on hand will greatly reduce the cleaning time, and differential pressure gauges, with alarms, can be supplied to get the maximum on-stream time between cleaning cycles.

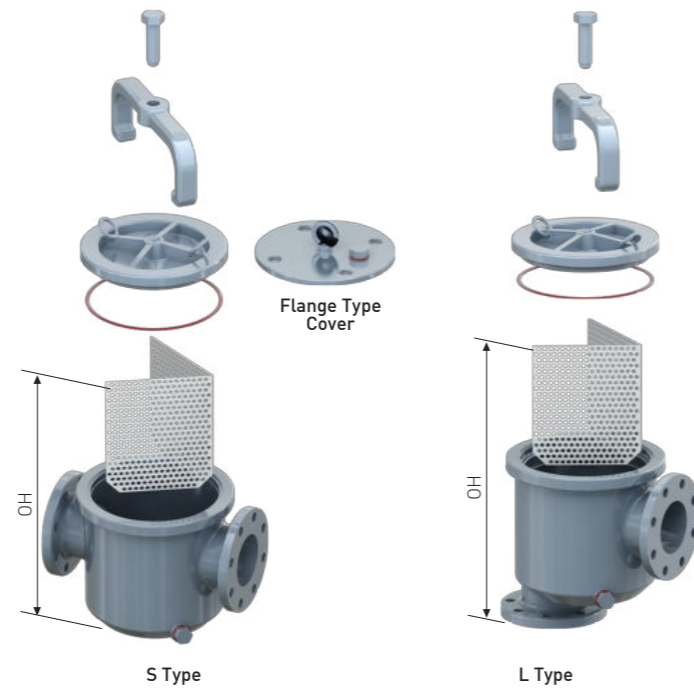
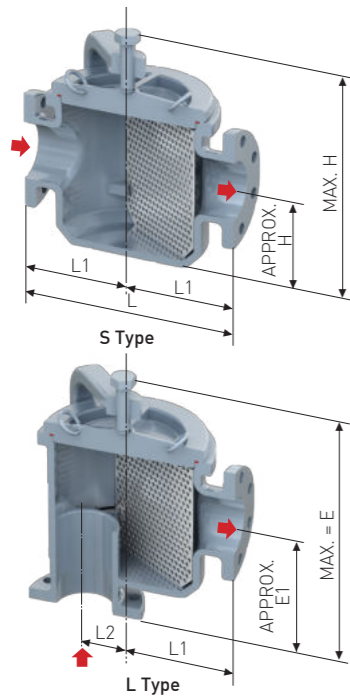

DIMENSION TABLE

Nominal dia	L1	L2	L	E1	E	H1	H	OH		DRAIN PLUG	Net Weight (kg)
								S-Type	L-Type		
25A	90	23	180	110	255	73	218	238	275	M16x2P	10
32A	90	23	180	110	255	73	218	238	275	M16x2P	11
40A	90	23	180	110	255	73	218	238	275	M16x2P	12
50A	120	40	240	135	280	90	235	296	341	M20x1.5P	22
65A	150	53	300	160	340	116	296	389	433	M20x1.5P	36
80A	160	55	320	180	375	131	326	436	485	M20x1.5P	40
100A	190	70	380	210	435	152	377	494	552	M20x1.5P	58
125A	235	88	470	285	560	214	489	674	745	M20x1.5P	97
150A	280	110	560	345	665	267	587	832	910	M24x2P	158
200A	330	135	660	440	845	330	735	1025	1135	M30x2P	259
250A	380	155	760	500	1025	400	925	1300	1400	M30x2P	447

* We can provide bigger size strainers.

MUD / ROSE BOXES
MUD BOXES FOR STEEL PLATE (M/N:MS1)

Specifications

Stress analysis code	ASME Section VIII Division 1.
Connection Flange	JIS B 2210, ANSI B 16.5, DIN, etc.
Materials	
Body	Carbon Steel, Stainless Steel, etc.
Filter	Carbon Steel, Stainless Steel, Monel, Titanium, etc.
Packing	N.B.R, E.P.D.M, P.T.F.E, Viton, etc.
Filter	ø2 - ø19
Mesh	N/A
Lifting	Handle, Davit, Lug, etc.
Cover bolting	Hinge, Stud, Hexagon, etc.
Vent / Drain type	Screw, Flange, Valve, etc.
Coating	Tar Free Epoxy, N.B.R, P.E, Hot Dipped Galv, etc.
Liquid name	Water, Oily Water, Gas, etc.



General

Mud Boxes for steel plate are available with bolted or quick release hinge bolted cover. Hinge bolted cover units are ideally suited for applications where frequent clean-out of the filter is expected. Having a spare, clean filter on hand will greatly reduce the cleaning time, and differential pressure gauges, with alarms, can be supplied to get the maximum on-stream time between cleaning cycles.

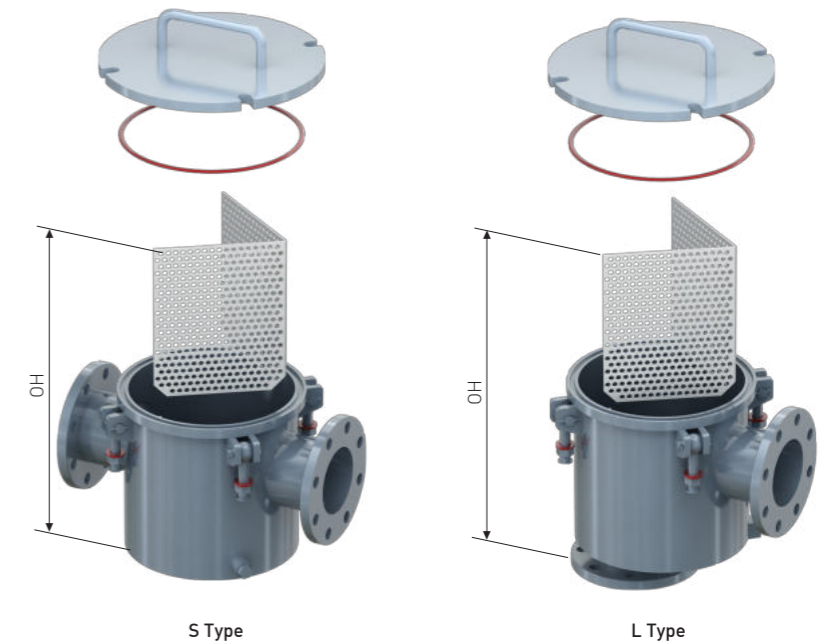
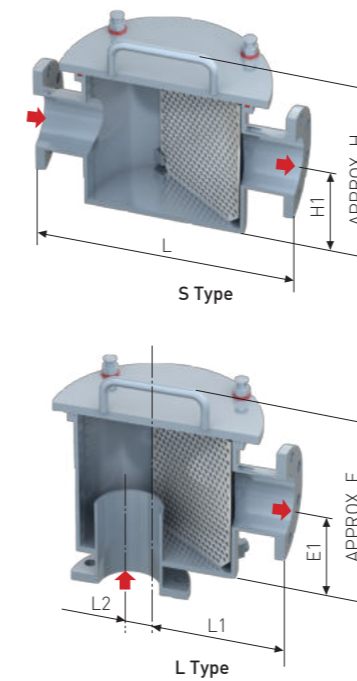

DIMENSION TABLE

Nominal dia	L	L1	L2	H	H1	E	E1	OH		DRAIN PLUG	Net Weight (kg)
								S Type	L Type		
100A	430	215	45	332	152	390	210	509	567	M20x1.5P	40
125A	545	273	50	436	214	507	285	691	762	M20x1.5P	69
150A	620	310	80	522	267	600	345	854	932	M20x1.5P	113
200A	750	375	90	631	330	741	440	1057	1167	M20x1.5P	191
250A	840	420	115	773	400	873	500	1355	1435	M20x1.5P	286
300A	840	420	85	784	410	884	510	1366	1457	M20x1.5P	296

* We can provide bigger size strainers.

MUD / ROSE BOXES
MUD BOXES FOR ROUND TYPE (M/N:MC2/MS2)

B
PRODUCT



Specifications

Stress analysis code	ASME Section VIII Division 1.
Connection Flange	JIS B 2210, ANSI B 16.5, DIN, etc.
Materials	
Body	Carbon Steel, Stainless Steel, etc.
Filter	Carbon Steel, Stainless Steel, Monel, Titanium, etc.
Packing	N.B.R, E.P.D.M, P.T.F.E, Viton, etc.
Filter	φ2 - φ19
Mesh	N/A
Lifting	Handle, Davit, Lug, etc.
Cover bolting	Stud, Hexagon, etc.
Vent / Drain type	Screw, Flange, Valve, etc.
Coating	Tar Free Epoxy, N.B.R, P.E, Hot Dipped Galv, etc.
Liquid name	Water, Oily Water, Gas, etc.

General

Mud boxes for round type are available with bolted or quick release hinge bolted cover. Hinge bolted cover units are ideally suited for applications where frequent clean-out of the filter is expected.

Having a spare, clean filter on hand will greatly reduce the cleaning time, and differential pressure gauges, with alarms, can be supplied to get the maximum on-stream time between cleaning cycles.

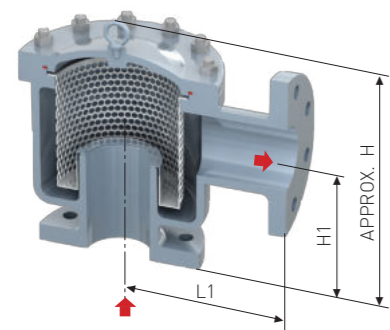

CASTING (M/N : MC2)

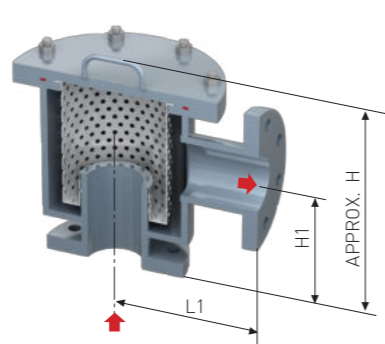

STEEL PLATE (M/N : MS2)

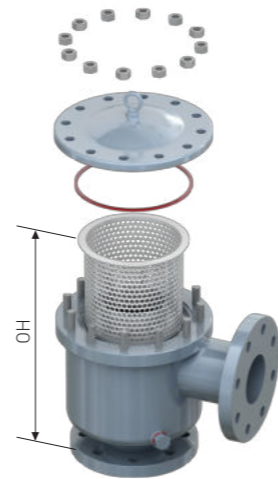

DIMENSION TABLE
[CASTING - MC2]

Nominal dia	L1	H	H1	OH	DRAIN	Net Weight(KG)
25A	90	255	110	275	M16x2P	8
32A	90	255	110	275	M16x2P	11
40A	90	255	110	275	M16x2P	11
50A	120	280	135	341	M20x1.5P	18
65A	150	340	160	433	M20x1.5P	35
80A	160	375	180	485	M20x1.5P	40
100A	190	435	210	552	M20x1.5P	54
125A	235	560	285	745	M20x1.5P	96
150A	280	665	345	910	M24x2P	151
200A	330	845	440	1135	M24x2P	258
250A	380	1025	500	1400	M24x2P	454

DIMENSION TABLE
[STEEL PLATE - MS2]

Nominal dia	L1	H	H1	OH	DRAIN	Net Weight(KG)
125A	545	507	285	762	M20x1.5P	69
150A	620	600	345	932	M20x1.5P	112
200A	750	741	440	1167	M20x1.5P	192
250A	840	873	500	1435	M20x1.5P	287
300A	840	884	540	1455	M20x1.5P	296

* We can provide bigger size strainers.

www.woosungflowtec.com

MUD / ROSE BOXES
ROSE BOXES FOR STEEL PLATE (M/N:RB)

B
PRODUCT

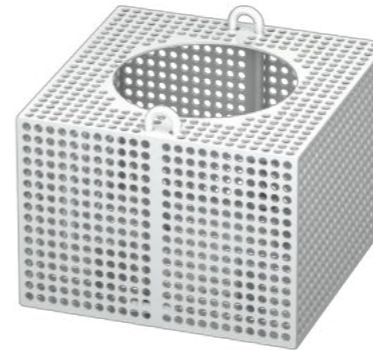

Specifications

Stress analysis code	ASME Section VIII Division 1.
Connection Flange	JIS B 2210, ANSI B 16.5, DIN, etc.
Materials	
Filter	Stainless Steel, Carbon steel, Monel, Titanium, etc.
Filter	φ2 - φ12
Cover bolting	N/A
Liquid name	Oil, Water, etc.

General

They shall be used for filtering that the collected bilge from each compartment. These type are installed for end position of suction piping line

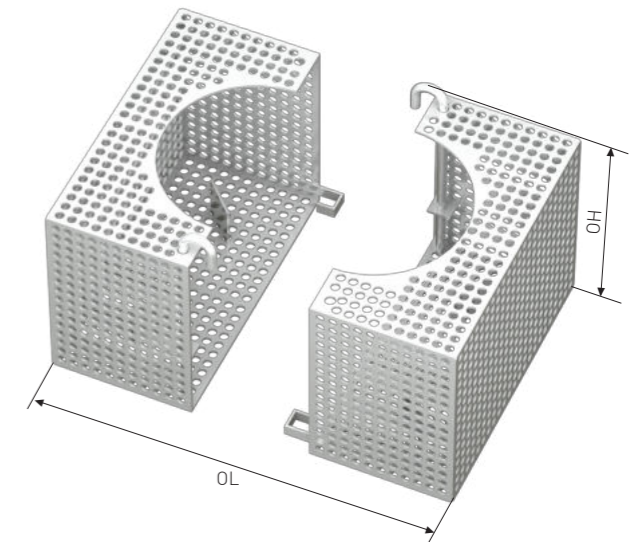
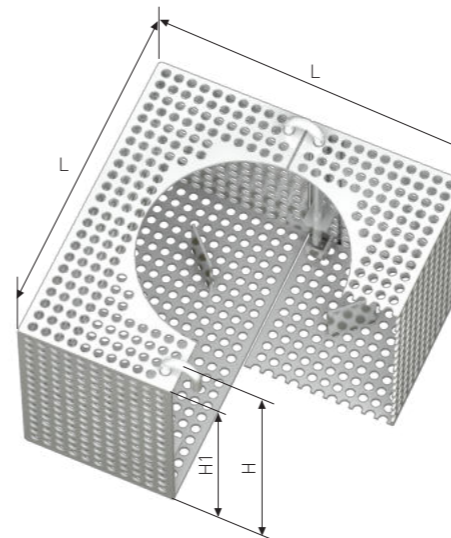

DIMENSION TABLE

Nominal dia	L	H1	H	OH	OL	Net Weight (kg)
25A	95	50	80	112	129	0.4
32A	95	65	90	122	138	0.5
40A	95	65	90	122	144	1
50A	110	80	105	144	171	2
65A	140	95	120	158	237	3
80A	170	110	135	173	260	4
100A	200	140	165	209	315	5
125A	260	170	200	244	400	7
150A	320	200	230	274	486	10
200A	380	260	300	360	597	21
250A	440	320	360	420	708	28
300A	500	350	400	470	819	36

* We can provide bigger size strainers.

www.woosungflowtec.com

B
PRODUCT

STRAINER

B
PRODUCT

REDUCING PIECE / ETC.

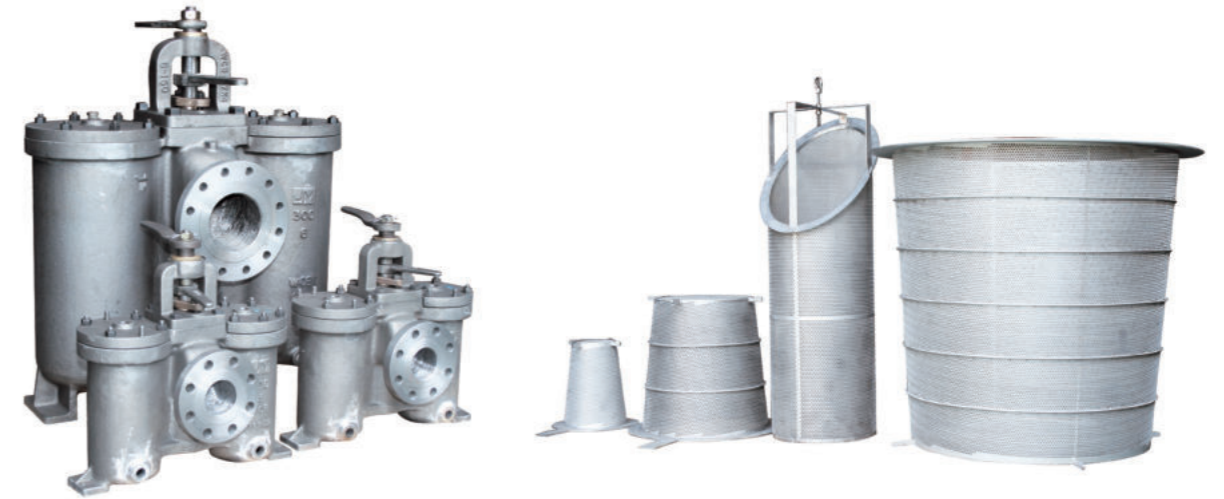
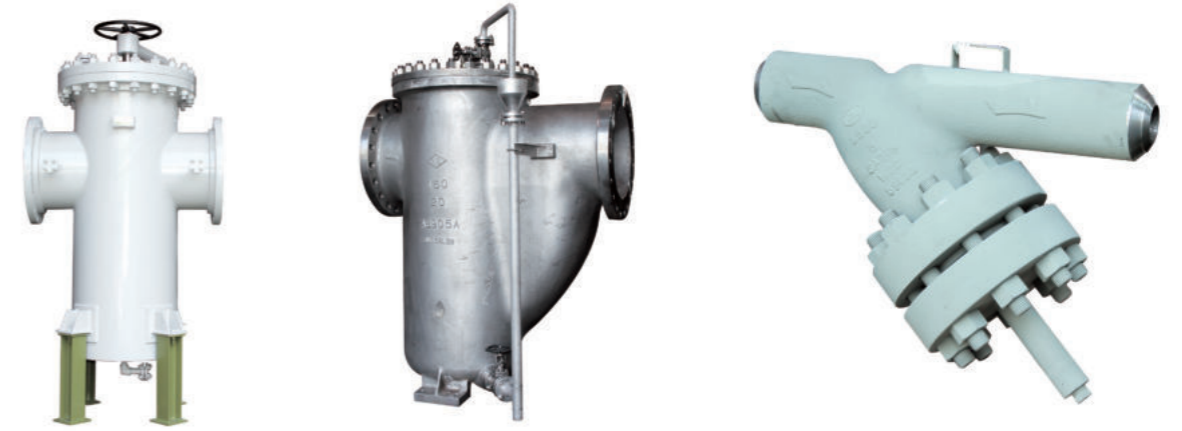

BELL MOUTH (M/N:RP)



REDUCING PIECE (M/N:RP)



MESH-MM CONVERSION & OPEN AREA CHART

MESH	WIRE DIA (mm)	OPENNING (mm/microns)	OPEN AREA(%)	SWG NO.	MESH	WIRE DIA (mm)	OPENNING (mm/microns)	OPEN AREA(%)	SWG NO.	
2	1.000	11.700 /11700	85	19	36	0.250	0.456 /456	42	33	
2.3	1.600	9.443 /9443	73	16	40	0.254	0.381 /381	36	33	
3	1.000	7.467 /7467	78	19		0.250	0.385 /385	37	33	
4	1.200	5.150 /5150	66	18		0.200	0.435 /435	47	36	
	1.000	5.350 /5350	71	19	0.180	0.455 /455	51	37		
5	0.900	5.450 /5450	74	20	50	0.250	0.258 /258	26	33	
	1.000	4.080 /4080	65	19		0.230	0.278 /278	30	34	
	0.900	4.180 /4180	68	20		0.200	0.308 /308	37	36	
6	0.800	4.280 /4280	71	21	60	0.180	0.328 /328	42	37	
	0.900	3.333 /3333	62	20		0.140	0.368 /368	53	39	
	0.800	3.433 /3433	66	21		0.200	0.223 /223	28	36	
	0.700	3.533 /3533	70	22		0.180	0.243 /243	33	37	
7	0.600	3.633 /3633	74	23	70	0.160	0.263 /263	39	38	
	0.800	2.829 /2829	61	21		0.140	0.283 /283	45	39	
	0.600	3.029 /3029	70	23		0.152	0.211 /211	34	38	
8	0.900	2.275 /2275	51	20	80	0.140	0.178 /178	31	39	
	0.800	2.375 /2375	56	21		0.120	0.198 /198	39	40	
	0.700	2.475 /2475	61	22		0.110	0.208 /208	43	41	
	0.600	2.575 /2575	66	23		0.100	0.218 /218	47	42	
	0.500	2.675 /2675	71	25		100	0.120	0.134 /134	28	40
0.450	2.725 /2725	74	26	0.110	0.144 /144		32	41		
0.800	1.740 /1740	47	21	0.100	0.154 /154		37	42		
10	0.700	1.840 /1840	53	22	120	0.080	0.174 /174	47	44	
	0.600	1.940 /1940	58	23		0.110	0.102 /102	23	41	
	0.500	2.040 /2040	65	25		150	0.100	0.112 /112	28	42
	0.450	2.090 /2090	68	26			0.080	0.132 /132	39	44
0.400	2.140 /2140	71	28	0.065	0.104 /104		38	46		
12	0.500	1.617 /1617	58	25	165	0.060	0.109 /109	42	46	
	0.450	1.667 /1667	62	26		0.050	0.119 /119	50	47	
	0.400	1.717 /1717	66	28		0.045	0.109 /109	50	48	
14	0.350	1.767 /1767	70	29	180	0.060	0.081 /81	33	46	
	0.500	1.314 /1314	53	25		0.053	0.088 /88	39	47	
	0.400	1.414 /1414	61	28		0.050	0.091 /91	42	47	
15	0.350	1.464 /1464	65	29	200	0.045	0.096 /96	46	48	
	0.600	0.988 /988	39	23		0.058	0.069 /69	30	47	
	0.500	1.088 /1088	47	25		0.053	0.074 /74	34	47	
	0.400	1.188 /1188	56	28		0.050	0.077 /77	37	47	
18	0.350	1.238 /1238	61	29	230	0.045	0.082 /82	42	48	
	0.290	1.298 /1298	67	31		0.040	0.087 /87	47	48	
	0.600	0.811 /811	33	23		0.035	0.075 /75	47	49	
	0.500	0.911 /911	42	25		250	0.045	0.057 /57	31	48
0.400	1.011 /1011	51	28	0.040	0.062 /62		37	48		
0.350	1.061 /1061	57	29	0.035	0.067 /67		43	49		
20	0.290	1.121 /1121	63	31	270	0.030	0.072 /72	50	49	
	0.500	0.770 /770	37	25		0.035	0.059 /59	39	49	
	0.400	0.870 /870	47	28		300	0.040	0.045 /45	28	48
	0.350	0.920 /920	53	29			0.035	0.050 /50	34	49
0.290	0.980 /980	60	31	0.030	0.055 /55		42	49		
24	0.400	0.658 /658	39	28	325	0.028	0.057 /57	45	50	
	0.350	0.708 /708	45	29		0.040	0.038 /38	24	48	
	0.290	0.768 /768	53	31		0.035	0.043 /43	31	49	
	0.250	0.808 /808	58	33		0.030	0.048 /48	38	49	
	0.230	0.828 /828	61	34		0.028	0.050 /50	41	50	
30	0.190	0.868 /868	67	36	350	0.035	0.038 /38	27	49	
	0.290	0.557 /557	43	31		0.030	0.043 /43	34	49	
	0.250	0.597 /597	50	33		400	0.030	0.034 /34	28	49
	0.230	0.617 /617	53	34			0.030	0.021 /21	17	49
0.220	0.627 /627	55	35	500	0.025	0.026 /26	26	50		



FLOW RATES IN PIPES REFERENCE

WALL THICKNESS STD. : ASME B36.10 B36.19

BORE	SECTION AREA ^{m²}	FLOW RATE IN PIPE(M ³ /hr)						
		0.5 m/s	1.0 m/s	1.5 m/s	2.0 m/s	2.5 m/s	3.0 m/s	
1/8	6	0.000037	0.066	0.132	0.198	0.264	0.330	0.396
1/4	8	0.000067	0.121	0.241	0.362	0.483	0.603	0.724
3/8	10	0.000123	0.222	0.443	0.665	0.886	1.108	1.330
1/2	15	0.000196	0.353	0.706	1.059	1.412	1.765	2.118
3/4	20	0.000344	0.619	1.239	1.858	2.477	3.096	3.716
1	25	0.000557	1.003	2.007	3.010	4.013	5.017	6.020
1 1/4	32	0.000964	1.736	3.472	5.207	6.943	8.679	10.415
1 1/2	40	0.00314	2.365	4.730	7.095	9.460	11.824	14.189
2	50	0.002165	3.897	7.793	11.670	15.586	19.483	23.378
2 1/2	65	0.003088	5.558	11.115	16.673	22.231	27.789	33.346
3	80	0.004769	8.583	17.167	25.750	34.334	42.917	51.501
3 1/2	90	0.006379	11.482	22.963	34.445	45.927	57.408	68.890
4	100	0.008213	14.783	29.567	44.350	59.134	73.917	88.700
5	125	0.012908	23.235	46.470	69.704	92.939	116.174	139.409
6	150	0.018646	33.563	67.125	100.688	134.250	167.813	201.375
8	200	0.032276	58.097	116.195	174.292	232.389	290.486	348.584
10	250	0.050856	91.541	183.082	274.623	366.164	457.704	549.245
12	300	0.072937	131.287	262.574	393.861	525.148	656.434	787.721
14	350	0.088954	160.116	320.233	480.349	640.466	800.582	960.698
16	400	0.117835	212.103	424.206	636.309	848.413	1060.516	1272.619
18	450	0.150770	271.386	542.773	814.159	1085.546	1356.932	1628.319
20	500	0.187759	337.966	675.933	1013.899	1351.866	1689.832	2027.798
22	550	0.228802	411.843	823.686	1235.529	1647.372	2059.215	2471.057
24	600	0.273898	493.016	986.032	1479.048	1972.064	2465.080	2958.096
26	650	0.323048	581.486	1162.971	1744.457	2325.943	2907.429	3488.914
28	700	0.376251	677.252	1354.504	2031.756	2709.008	3386.260	4063.512
30	750	0.433508	780.315	156.630	2340.945	3121.259	3901.574	4681.889
32	800	0.494819	890.674	1781.349	2672.023	3562.697	4453.371	5344.046
34	850	0.560184	1008.330	2016.661	3024.991	4033.321	5041.652	6049.982
36	900	0.629602	1133.283	2266.566	3399.849	4533.132	5666.415	6799.698
38	950	0.703073	1265.532	2531.064	3796.597	5062.129	6327.661	7593.193
40	1000	0.780599	1405.078	2810.156	4215.234	5620.312	7025.390	8430.468
42	1050	0.862194	1551.950	3103.900	4655.850	6207.800	7759.750	9311.700
44	1100	0.947828	1706.090	3412.181	5118.271	6824.362	8530.452	10236.542
46	1150	1.037515	1867.527	3735.055	5602.582	7470.110	9337.637	11205.165
48	1200	1.131256	2036.261	4072.522	6108.783	8145.044	1081.305	12217.566



OPENING RATIO CALCULATION

PERFORATED PLATE.(60° ~ZIG ZAG)

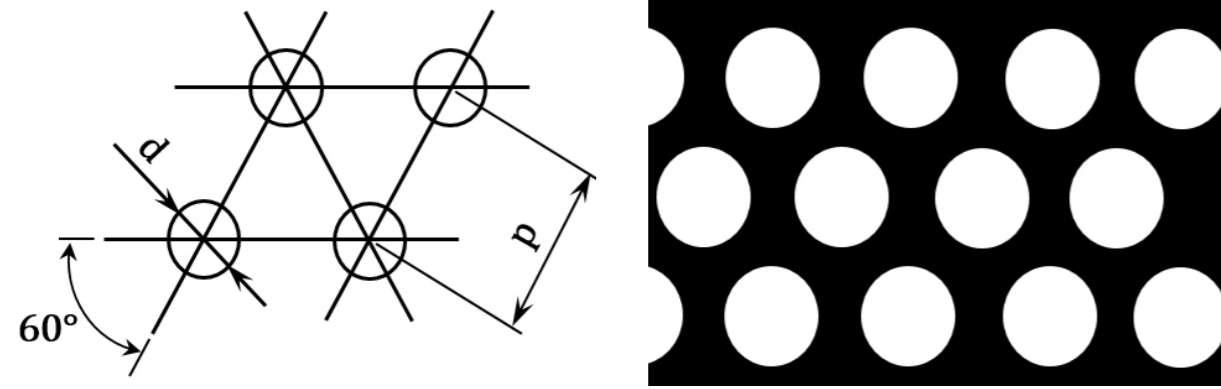

OPEN AREA RATIO(%) = 0.91 X (d/p)² X 100

Here is, | d : PORE DIAMETER(mm)
p : PITCH(mm)

MESH(PLAIN WEAVE)

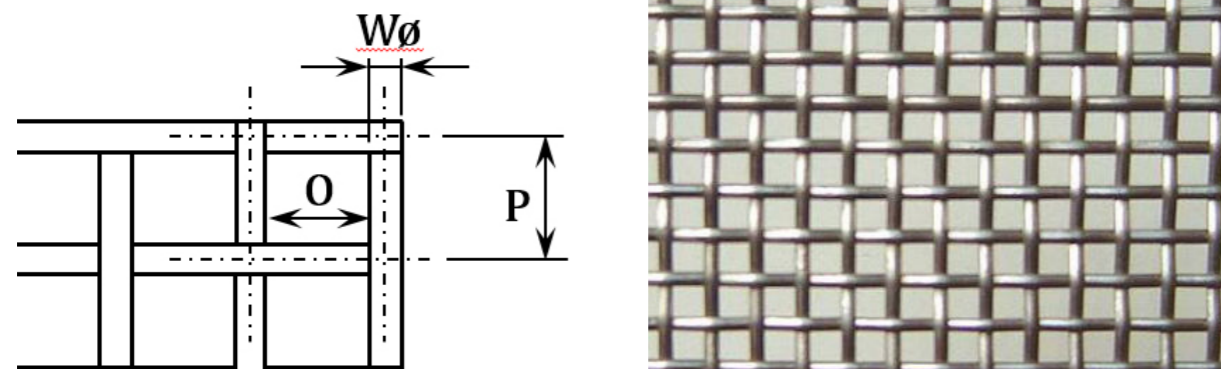

P = 25.4/n OPEN AREA RATIO(%) = (O/P)² X 100 = (P-W/P)² X 100

Here is, | P : PITCH(mm)
n : MESH NUMBER(mm)
W : WIRE DIAMETER(mm)
O : OPENING(mm)



CONVERSION OF UNITS

PRESSURE FACTORS	1kg/cm ²	= 980665 μbar = 980.665 mbar = 0.981 bar = 98066.5 Pa = 980.665 hPa = 98.067 kPa = 0.0981 MPa = 14.223 psi = 14.223 x 10 ⁻³ ksi = 14.223 x 10 ⁻⁶ Mpi
FLOW FACTORS	1 m ³ /hr	= 100000 cm ³ /hr = 16666.67 cm ³ /min = 277.778 cm ³ /sec = 8.387 bbl/h = 264.18 US gal/hr = 4.403 US gal/min(G.P.M)
TEMPERATURE FACTORS	1 °C	= 33.8°F [where, °C = [5/9] x [°F-32]]

To better technology...

As inexpensive insurance, STRAINERS from WOOSUNG FLOWTEC Co., Ltd. have widely applied and utilized in Offshore plant (FPSO, Drill ship, Platform, etc.), Onshore plant(Oil & Gas industry, Petrochemistry, Power Plant, Fresh water, unit, etc.) And we have consistently exported STRAINERS, FILTERS, and PIPE FITTINGS to USA, Japan, Singapore, Saudi Arabia, UAE, Thailand, Algeria, India, Brazil, etc. with certified quality. WOOSUNG FLOWTEC has done our best to globalize by exporting our products to world-wide.

